

SIGSAUER®



SIG716® TREAD



READ THE INSTRUCTIONS AND WARNINGS IN THIS MANUAL CAREFULLY BEFORE USING THIS FIREARM. DO NOT DISCARD THIS MANUAL. THIS MANUAL SHOULD ALWAYS ACCOMPANY THIS FIREARM AND BE TRANSFERRED WITH IT UPON CHANGE IN OWNERSHIP, OR WHEN THE FIREARM IS PRESENTED TO ANOTHER PERSON.



WARNINGS

1.0 SAFETY WARNINGS

Read this entire manual thoroughly and carefully prior to using this SIG SAUER firearm.

The warnings in this operator's manual are important. By understanding the dangers inherent in the use of any firearm and by taking the precautions described in this manual, you can experience a higher level of safety in the use of your firearm. Failure to heed any of these warnings may result in serious injury or death to you or others as well as severe damage to the firearm or other property.

As a valued SIG SAUER customer, we encourage you to visit sigsauer.com. There, you will find links to product information and updates, merchandise promotions, and educational videos that will be of interest to you as an owner of SIG SAUER products.

SIG SAUER firearms are designed to function reliably with proper care and knowledgeable use. You must understand the safe operation and use of your SIG SAUER firearm. Carefully read and follow these instructions. Do not use the firearm unless you fully understand these instructions and the safe operation of your firearm. Failure to heed any of these instructions may result in serious injury or death to you or others as well as severe damage to the firearm or other property.

Your firearm comes equipped with effective, well-designed safety features. However, never rely completely on any safety mechanism. Safety mechanisms are designed to augment, not replace, safe handling practices. Careless and improper handling of any firearm can result in an unintentional discharge. Practicing safe firearm handling habits will ensure the safe use of your firearm. Like all mechanical devices, the safety is subject to breakage or malfunction and can be adversely affected by wear, abuse, dirt, corrosion, incorrect assembly, improper adjustment or repair, or lack of maintenance. Moreover, there is no such thing as a safety that is "childproof" or that can completely prevent unintentional discharge from improper usage, carelessness, or "horseplay."

The best safety is proper and applied training in safe firearms handling. Always handle your firearm as though you expect the safeties not to work.

Do not load a cartridge into the chamber until you are ready to use the firearm. If your firearm is equipped with a manual safety, keep the safety ON and your finger off the trigger until you are ready to fire. Always move the safety selector lever to its fully engaged position and visually check it. The safety selector lever is not ON unless it is in its fully engaged position.

ABUSIVE HANDLING

SIG SAUER firearms incorporate effective mechanical safeties. However, like any mechanical device, exposure to abusive conditions may have a negative effect on these safety mechanisms and cause them to fail to work as designed. Do not subject your SIG SAUER firearm to any type of abusive handling. This includes the firearm being dropped, impact to the firearm, or the firearm being struck by another object. Make sure you always maintain control of your firearm at all times. If your firearm does suffer an abusive event such as previously described, do not attempt to use the firearm. Keep the firearm pointed in a safe direction, unload and clear the firearm of all ammunition immediately, and have it inspected by a certified SIG SAUER armorer or gunsmith prior to using the firearm.

A safe direction is defined as an area in which, if the firearm were to discharge, no property damage would occur and no personal injury would result.

Intentional or repetitive abusive handling of any SIG SAUER firearm will void the manufacturer's warranty and could render the firearm unsafe.



1.0 SAFETY WARNINGS - Continued

REPLACEMENT PARTS

Do not attempt to disassemble your SIG SAUER firearm beyond the point explained in this manual. Disassembly beyond the instructions in this manual is restricted to a certified SIG SAUER armorer or professional gunsmith. Failure to comply with these restrictions will void your warranty.

Warnings and instructions about the use of some SIG SAUER replacement parts, assemblies, and accessories may be described in literature accompanying the specific products. Read and carefully follow those instructions. Such warnings and instructions are provided to assure the safe functioning of the firearm. Failure to heed them may result in improper functioning, damage to the firearm, and serious injury or death to yourself or others.

ALTERATIONS

This SIG SAUER firearm was designed to function properly in its original condition. Unauthorized alterations can make it unsafe. Do not alter any part or add or substitute any parts or accessories not manufactured by SIG SAUER for this firearm. The addition of any parts or accessories beyond the user level of maintenance described in this manual is not authorized.

ACCESSORIES

It is your responsibility to ensure that all accessories, are compatible with this firearm and that the accessories do not interfere with the safe operation and handling of the firearm.

TRANSPORTING

When transporting your firearm, be sure the firearm is unloaded and cleared of all ammunition. It is your responsibility to familiarize yourself with the laws of any state you will be traveling through with your firearm.

STORAGE

The only safe way to store your firearm is unloaded, cleared of all ammunition, and secure. Safe and secure storage is one of your most important responsibilities. Store your unloaded firearm separate from your ammunition and in places inaccessible to children and unauthorized persons.

CHAMBER SAFETY FLAG

Every SIG SAUER firearm is shipped with a chamber safety flag. The chamber safety flag prevents the chambering of a round when installed and provides a readily visible indication that the firearm's chamber is empty. The chamber safety flag is to be installed in the firearm's chamber at all times when the firearm is not in use. Many public ranges require chamber safety flags be installed when the firing line is cold.



1.0 SAFETY WARNINGS - Continued

LIABILITY

This product is classified as a Firearm and is sold by SIG SAUER with the specific understanding that we shall not be responsible in any manner whatsoever for malfunctioning of the firearm, physical injury, or property damage resulting in whole or in part from:

- Criminal or negligent discharge
- Improper, careless, or abusive handling
- Unauthorized modifications or parts replacement
- Defective, improper, hand-loaded, or reloaded ammunition
- Corrosion
- Neglect
- Other influences beyond our direct and immediate control

This limitation applies regardless of whether liability is asserted on the basis of contract, negligence, or strict liability (including any failure to warn). Under no circumstance shall SIG SAUER, Inc. be liable for incidental or consequential damages, such as loss of use of property, commercial loss, and loss of earnings or profits.

THE BASIC RULES OF SAFE FIREARMS HANDLING

1. ALWAYS treat every firearm as if it were loaded.
2. ALWAYS be sure that the barrel is clear of any obstruction.
3. ALWAYS be sure of your backstop, what lies beyond, and the safety of bystanders before you shoot.
4. ALWAYS use clean, dry, original factory-made ammunition of the proper type and caliber for your firearm.
5. ALWAYS wear ear protection and safety glasses when shooting.
6. ALWAYS carry your firearm so that you can control the direction of the muzzle if you fall or stumble.
7. NEVER shoot at a flat surface or water.
8. DO NOT leave an unattended firearm loaded. Firearms and ammunition should be stored separately, locked if possible, beyond the reach of children, careless adults, or unauthorized users.
9. NEVER allow your firearm to be used by anyone who has not read and understood this operator's manual.
10. DO NOT point any firearm, loaded or unloaded, at any undesired target.
11. NEVER discharge your firearm near an animal unless the animal is trained to accept the noise: an animal's startled reaction could injure it or cause an accident.
12. NEVER drink alcoholic beverages or use drugs before or during shooting, as your vision and judgment could be seriously impaired, making your firearm handling unsafe.



1.1 EYE AND EAR PROTECTION



Always wear safety glasses that meet the requirements of American National Standards Institute (ANSI) z87.1 and ear plugs and “ earmuff ” type protectors whenever you are shooting. Always make certain that persons close to you are similarly protected. Unprotected eyes may be injured by powder, gas, carbon residue, lubricant, metallic particles, or similar debris that may emanate occasionally from any firearm in normal use. Without ear protection, repeated exposure to shooting noise may lead to cumulative, permanent hearing loss.

1.2 AMMUNITION

Use only high-quality, original, factory-manufactured ammunition. Do not use cartridges that are dirty, wet, corroded, bent, or damaged. Do not lubricate cartridges. Do not spray aerosol-type lubricants, preservative, or cleaners directly onto cartridges or where excess spray may flow into contact with cartridges. Lubricant or other foreign matter on cartridges can cause potentially dangerous ammunition malfunctions. Use only ammunition of the caliber for which your firearm is chambered. The proper caliber is permanently engraved on your firearm; never attempt to use ammunition of any other caliber.

The use of reloaded, “re-manufactured” hand-loaded, or other nonstandard ammunition voids all warranties. Reloading is a science and improperly loaded ammunition can be extremely dangerous. Severe damage to the firearm and serious injury or death to the shooter or to others may result. Always use ammunition that complies with the industry performance standards established by the Sporting Arms and Ammunition Manufacturers’ Institute, Inc. (SAAMI) or ammunition manufactured to military specifications.

SIG SAUER, Inc., specifically disclaims responsibility for any damage or injury whatsoever occurring in connection with, or as a result of, the use in any SIG SAUER firearm of faulty, nonstandard, “re-manufactured” hand-loaded (reloaded) ammunition, or cartridges other than those for which the firearm was originally chambered.

Firearms may be severely damaged and serious injury or death to the shooter or to others may result from any condition causing excessive pressure inside the chamber or barrel during firing. Excessive pressure can be caused by obstructions in the barrel, propellant powder overloads, the use of incorrect cartridges, or defectively assembled cartridges. In addition, the use of a dirty, corroded, or damaged cartridge can lead to a burst cartridge case and consequent damage to the firearm and personal injury from the sudden escape of high-pressure propellant gas within the firearm’s mechanism.

OBSTRUCTED BORE

Immediately stop shooting, keep the muzzle pointed in a safe direction and place the firearm on SAFE whenever:

- You have difficulty in, or feel unusual resistance in, chambering a cartridge;
- A cartridge misfires (does not go off);
- A fired case fails to extract;
- Unburned grains of propellant powder are discovered spilled in the mechanism;
- A shot sounds weak or abnormal. In such cases, it is possible that a bullet is lodged part way down the barrel.



1.2 AMMUNITION - Continued

Bullets can become lodged in the barrel:

- If the cartridge has been improperly loaded without propellant powder, or if the powder fails to ignite (ignition of the cartridge primer alone will push the bullet out of the cartridge case, but usually does not generate sufficient energy to expel the bullet completely from the barrel);
- If the bullet is not properly seated in the cartridge case. When such a cartridge is extracted from the chamber without being fired, the bullet may be left behind in the bore at the point where the rifling begins. Subsequent chambering of another cartridge may push the first bullet further into the bore.

If there is any reason to suspect that a bullet is obstructing the barrel, immediately unload and clear the firearm of all ammunition. Place the firearm on safe. Visually inspect the bore. It is not sufficient to merely look in the chamber. A bullet may be lodged some distance down the barrel where you cannot easily see it. If a bullet is in the bore, do not attempt to shoot it out by using another cartridge or by blowing it out with a blank or one from which the bullet has been removed. Such techniques can generate excessive pressure, damage the firearm, and cause serious personal injury.

If the bullet can be removed by using a cleaning rod, clean any unburned powder grains from the bore, chamber, and fire control assembly before resuming shooting. If the bullet cannot be dislodged by tapping it with a cleaning rod, take the firearm to a gunsmith.

Dirt, corrosion, or other foreign matter on a cartridge can impede complete chambering and may cause the cartridge case to burst upon firing. A damaged or deformed cartridge may also impede chambering or cause the cartridge case to burst upon firing.

Do not lubricate cartridges, and be sure to wipe the chamber clean of any oil or preservative before shooting. Oil interferes with the friction between cartridge case and chamber wall that is necessary for safe functioning, and subjects the firearm to stress similar to that imposed by excessive pressure.

Use lubricants sparingly on the moving parts of your firearm. Avoid excessive spraying of any aerosol gun care product, especially where it might get on ammunition. All lubricants and aerosol spray lubricants in particular can penetrate cartridge primers and cause misfires. Some highly penetrative lubricants can also migrate inside cartridge cases and cause deterioration of the propellant powder; on firing, the powder might not ignite. If only the primer ignites, there is danger that the bullet may become lodged in the barrel.

Death, serious injury, and damage to the firearm can result from the use of wrong ammunition, bore obstructions, powder overloads, or incorrect cartridge components. Always wear shooting glasses and hearing protection.



WARNING: CANCER AND REPRODUCTIVE HARM—www.P65warnings.ca.gov



DISCHARGING FIREARMS IN POORLY VENTILATED AREAS, CLEANING FIREARMS, OR HANDLING AMMUNITION MAY RESULT IN EXPOSURE TO LEAD AND OTHER SUBSTANCES KNOWN TO CAUSE BIRTH DEFECTS, REPRODUCTIVE HARM, AND OTHER SERIOUS PHYSICAL INJURY. MAINTAIN ADEQUATE VENTILATION AT ALL TIMES. WASH HANDS THOROUGHLY AFTER EXPOSURE. SHOOTING OR CLEANING FIREARMS MAY EXPOSE YOU TO LEAD.



1.3 STATE-BY-STATE WARNINGS

Certain states require, by law, that their own specified warning notices, in larger-than-normal type be conspicuously included by the manufacturer, distributor, or retail dealer with firearms sold in that state. SIG SAUER sells its products in compliance with applicable laws and regulations. Because our products may be sold in these states, we include the following:

CALIFORNIA:



WARNING

Firearms must be handled responsibly and securely stored to prevent access by children and other unauthorized users. California has strict laws pertaining to firearms, and you may be fined or imprisoned if you fail to comply with them. Visit the Web site of the California Attorney General at <https://oag.ca.gov/firearms> for information on firearm laws applicable to you and how you can comply. Prevent child access by always keeping guns locked away and unloaded when not in use. If you keep a loaded firearm where a child obtains and improperly uses it, you may be fined or sent to prison.”

If you or someone you know is contemplating suicide, please call the National Suicide Prevention Lifeline at 1-800-273 TALK (8255).



ADVERTENCIA

Las armas de fuego deben manipularse de manera responsable y segura para evitar el acceso de niños y otros usuarios no autorizados. California tiene leyes estrictas relacionadas con armas de fuego, y usted puede ser multado o encarcelado si no las cumple. Visite el sitio web del fiscal general de California en <https://oag.ca.gov/firearms> para obtener información sobre las leyes de armas de fuego que son aplicables y cómo puede cumplirlas. Evite el acceso de niños manteniendo siempre las armas bloqueadas y descargadas cuando no estén en uso. Si mantiene un arma de fuego cargada donde un niño la puede obtener y la usa indebidamente, se le puede multar o enviar a prisión.

Si usted o alguien que conoce está contemplando el suicidio, llame a la Línea Nacional de Prevención del Suicidio al 1-800-273 TALK (8255).

CONNECTICUT:

“UNLAWFUL STORAGE OF A LOADED FIREARM MAY RESULT IN IMPRISONMENT OR FINE.”

FLORIDA:

“IT IS UNLAWFUL, AND PUNISHABLE BY IMPRISONMENT AND FINE, FOR ANY ADULT TO STORE OR LEAVE A Firearm IN ANY PLACE WITHIN THE REACH OR EASY ACCESS OF A MINOR UNDER 18 YEARS OF AGE OR TO KNOWINGLY SELL OR OTHERWISE TRANSFER OWNERSHIP OR POSSESSION OF A Firearm TO A MINOR OR A PERSON OF UNSOUND MIND.”



MASSACHUSETTS:

“WARNING FROM THE MASSACHUSETTS ATTORNEY GENERAL:

This handgun is not equipped with a device that fully blocks use by unauthorized users. More than 200,000 firearms like this one are stolen from their owners every year in the United States. In addition, there are more than a thousand suicides each year by younger children and teenagers who get access to firearms. Hundreds more die from accidental discharge. It is likely that many more children sustain serious wounds, or inflict such wounds accidentally on others. In order to limit the chance of such misuse, it is imperative that you keep this firearm locked in a secure place and take other steps necessary to limit the possibility of theft or accident. Failure to take reasonable preventative steps may result in innocent lives being lost, and in some circumstances may result in your liability for these deaths.”

“IT IS UNLAWFUL TO STORE OR KEEP A FIREARM, SHOTGUN OR MACHINE GUN IN ANY PLACE UNLESS THAT FIREARM IS EQUIPPED WITH A TAMPER RESISTANT SAFETY DEVICE OR IS STORED OR KEPT IN A SECURELY LOCKED CONTAINER.”

MAINE:

“ENDANGERING THE WELFARE OF A CHILD IS A CRIME. IF YOU LEAVE A FIREARM AND AMMUNITION WITHIN EASY ACCESS OF A CHILD, YOU MAY BE SUBJECT TO FINE, IMPRISONMENT OR BOTH. KEEP FIREARMS AND AMMUNITION SEPARATE. KEEP FIREARMS AND AMMUNITION LOCKED UP. USE TRIGGER LOCKS.”

MARYLAND:

“WARNING: Children can operate firearms which may cause death or serious injury. It is a crime to store or leave a loaded firearm in any location where an individual knew or should have known that an unsupervised minor would gain access to the firearm. Store your firearm responsibly!”

NEW JERSEY:

“IT IS A CRIMINAL OFFENSE TO LEAVE A LOADED FIREARM WITHIN EASY ACCESS OF A MINOR.”

NEW YORK CITY, NY:

“THE USE OF A LOCKING DEVICE OR SAFETY LOCK IS ONLY ONE ASPECT OF RESPONSIBLE Firearm STORAGE. ALL FIREARMS SHOULD BE STORED UNLOADED AND LOCKED IN A LOCATION THAT IS BOTH SEPARATE FROM THEIR AMMUNITION AND INACCESSIBLE TO CHILDREN AND ANY OTHER UNAUTHORIZED PERSONS. NEW YORK CITY LAW PROHIBITS, WITH CERTAIN EXCEPTIONS, ANY PERSON FROM ACQUIRING MORE THAN ONE FIREARM, OR MORE THAN ONE FIREARM OR SHOTGUN, WITHIN A 90-DAY PERIOD.”



NORTH CAROLINA:

Any person who resides in the same premises as a minor, owns or possesses a firearm, and stores or leaves the firearm (i) in a condition that the firearm can be discharged and (ii) in a manner that the person knew or should have known that an unsupervised minor would be able to gain access to the firearm, is guilty of a Class 1 misdemeanor if a minor gains access to the firearm without the lawful permission of the minor's parents or a person having charge of the minor and the minor:

- (1) Possesses it in violation of G.S. 14-269.2(b)
- (2) Exhibits it in a public place in a careless, angry, or threatening Manner;
- (3) Causes personal injury or death with it not in self defense; or
- (4) Uses it in the commission of a crime.

TEXAS:

"IT IS UNLAWFUL TO STORE, TRANSPORT, OR ABANDON AN UNSECURED FIREARM IN A PLACE WHERE CHILDREN ARE LIKELY TO BE AND CAN OBTAIN ACCESS TO THE FIREARM."

WISCONSIN:

"IF YOU LEAVE A LOADED FIREARM WITHIN THE REACH OR EASY ACCESS OF A CHILD YOU MAY BE FINED OR IMPRISONED OR BOTH IF THE CHILD IMPROPERLY DISCHARGES, POSSESSES, OR EXHIBITS THE FIREARM."

Please check with your licensed retailer, state police, or local police for additional warnings, which may be required by local law or regulation. Such regulations change constantly, and local authorities are in the best position to advise you on such legal matters.

1.4 LOCKING DEVICES



This firearm was originally sold with a key-operated locking device. Although it can help provide secure storage for your unloaded firearm, any locking device can fail. All firearms are designed to fire if they are loaded and the trigger is pressed. Therefore, never install the locking device inside the trigger guard or in any way that makes it possible to press the trigger! Do not leave the keys in the lock.

The ultimate responsibility for secure storage of any firearm must depend upon its owner and his or her individual circumstances. Firearms should be stored unloaded, in a secure location, separate

from their ammunition. To maximize effectiveness and reduce the chances of malfunction or damage to a firearm, ALWAYS refer to the locking device's manufacturer instructions for installation and removal of the device.

1.5 SAFETY INFORMATION

FIREARMS SAFETY IS YOUR RESPONSIBILITY

This operator's manual is designed to assist you in learning how to use and care for your SIG SAUER® firearm properly. Only when you are certain that you fully understand this manual and can properly carry out its instructions, should you practice loading and firing your firearm with live ammunition. Having a firearm in your possession is a full-time job; you cannot guess and you cannot forget. You must know how to use your firearm safely.



If you have any doubts about your ability to handle or use this firearm safely, you should seek supervised instruction. The SIG SAUER Academy® provides all levels of firearms safety and skill training, from beginner to expert.

For more information contact:

SIG SAUER[®]
ACADEMY

sigsaueracademy.com • (603) 610-3400

Epping, New Hampshire

SAFETY MUST BE THE FIRST AND CONSTANT CONSIDERATION OF EVERY PERSON WHO HANDLES FIREARMS
AND AMMUNITION.

For more information about safety, responsible firearms ownership, and shooting sports, contact:

National Rifle Association (NRA) of America
11250 Waples Mill Road, Fairfax, VA 22030-7400 • 1-800-672-3888
nra.org

THIS PAGE INTENTIONALLY LEFT BLANK



Contents

1.0 SAFETY WARNINGS.....	2
1.1 EYE AND EAR PROTECTION.....	8
1.2 AMMUNITION	8
1.3 STATE-BY-STATE WARNINGS.....	12
1.4 LOCKING DEVICES.....	17
1.5 SAFETY INFORMATION	17
2.0 Mechanical Characteristics and Rifle Theory.....	22
2.1 Rifle Description	22
2.2 Specifications.....	23
2.3 Controls and Features.....	24
2.4 Groups and Assemblies	26
2.5 Cycle of Function	31
3.0 Operating the SIG716 TREAD	34
3.1 Preparation before using the firearm.	34
3.2 Selecting Modes of Fire	35
3.3 Loading / Reloading.....	36
3.3.2 Clear the SIG716 TREAD prior to loading	37
3.3.2 Clear the SIG716 TREAD prior to loading - Continued.....	38
3.5 Firing.....	43
3.7 Buttstock	46
4.0 User Level Authorized Preventive Maintenance.....	47
4.1 Field Strip the SIG716 TREAD	47
4.2 Detailed Disassembly of Bolt Carrier Assembly.....	50
4.3 Removal of Buffer and Action Spring.....	52
4.4 Disassemble Magazine	53

5.0 Cleaning/Lubrication	54
5.1 Cleaning Chamber and Bore of Barrel	54
5.2 Cleaning Bolt Carrier Assembly	55
5.3 Cleaning Upper/Lower Receivers	55
5.4 Lubrication.....	56
5.4.1 Bolt Carrier Assembly	56
6.0 Assembly	58
6.1 Assemble Magazine.....	58
6.2 Recoil Buffer and Action Spring	58
6.3 Assemble Bolt Carrier Group	60
6.4 Final Assembly.....	63
6.4 Final Assembly - Continued	64
7.0 Function Check	65
9.0 Storage	68
10.0 Parts Diagrams	70
10.1 Upper Receiver Assembly Parts Diagram	70
10.2 Upper Receiver Assembly Parts List	71
10.3 Lower Receiver Assembly Parts Diagram.....	72
10.4 Lower Receiver Assembly Parts List.....	72
11.0 Service and Replacement Parts Policy.....	73
12.0 Shipping Firearms for Repair	75
SIG SAUER® Limited Lifetime Firearms Warranty	77



2.0 Mechanical Characteristics and Rifle Theory

2.1 Rifle Description

2.1.1 General

The SIG716 TREAD rifle is a direct impingement rifle with a rotary bolt mechanism capable of semi-automatic operation. Semi-Automatic is defined as one round being fired each time the trigger is pressed to the rear. The trigger must be released by the user to reset for the next round. The rifle is chambered in 7.62x51mm NATO.

The SIG716 TREAD rifle is equipped with an aluminum handguard featuring a MIL-STD 1913 rail along the top of the handguard and multiple M-LOK® mounting points for attaching accessories.

2.2 Specifications

CALIBER	7.62X51mm NATO
LENGTH (STOCK EXTENDED)	37.52 in. (953 mm)
LENGTH (STOCK COLLAPSED)	34.21 in. (869 mm)
HEIGHT	7.44 in. (189 mm)
BARREL LENGTH	16.00 in. (406 mm)
RATE OF TWIST/ LANDS-GROOVES	1:10 in. (1:254 mm) /6 RH
WEIGHT (W/O MAGAZINE)	8.16 lb. (3.7 kg)
TRIGGER WEIGHT	5.5 - 9.5 lb. (2.49-4.31 kg)
MAGAZINE	20 ROUND COMPOSITE
STOCK	6 POSITION TELESCOPING
GRIP	COMPOSITE W/ STORAGE COMPARTMENT



2.3 Controls and Features

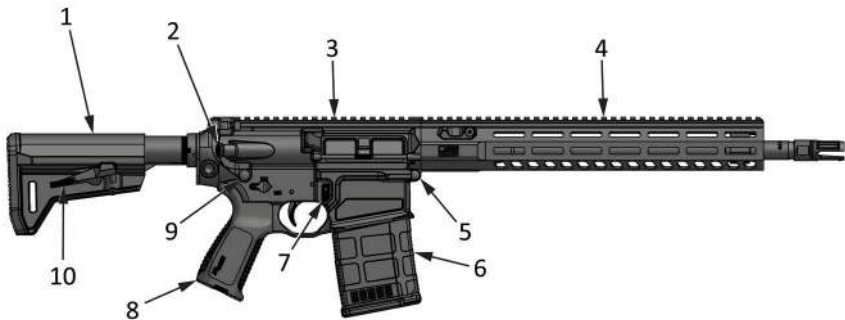

1. Buttstock
2. Forward Assist
3. Upper Receiver
4. M-LOK Handguard
5. Pivot Pin
6. Magazine
7. Magazine Release Button
8. Grip
9. Takedown Pin
10. Stock Latch

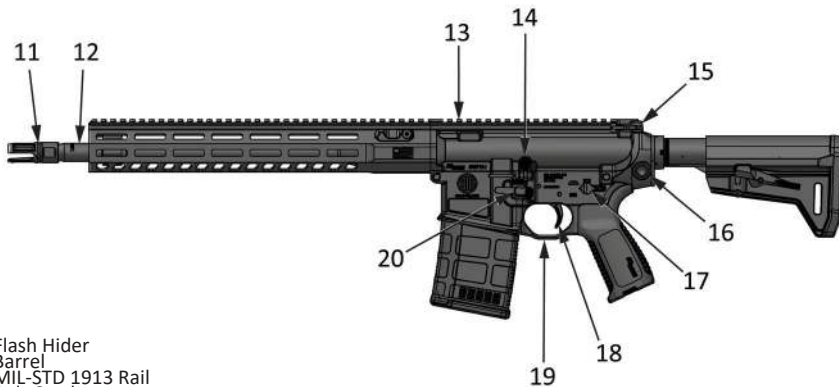

- 11. Flash Hider
- 12. Barrel
- 13. MIL-STD 1913 Rail
- 14. Bolt Catch
- 15. Charging Handle
- 16. Quick Detach Sling Point
- 17. Safety Selector Lever
- 18. Trigger
- 19. Trigger Guard
- 20. Ambidextrous Magazine Catch



2.4 Groups and Assemblies

2.4.1 Upper Receiver Group



(a) Charging Handle Assembly



(b) Bolt Carrier Assembly

The bolt carrier group consists of the bolt assembly, cam pin, bolt carrier, firing pin and firing pin retaining pin. The bolt assembly consists of the bolt, extractor, extractor spring, ejectors, ejector springs, and spiral gas ring.

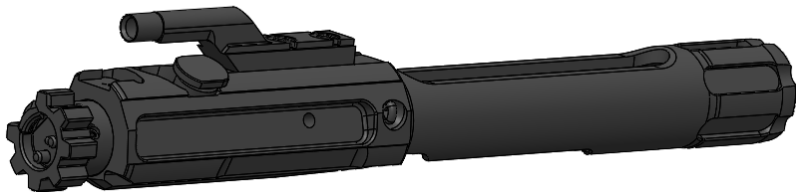



2.4.1 Upper Receiver Group - Continued

(c) Barrel Assembly

The barrel is mechanically mated to the receiver by means of a barrel nut, and the barrel extension. The flash suppressor is screwed onto the muzzle end of the barrel via 5/8 x 24 TPI threads. The gas block, which is pinned to the barrel, contains the gas tube.



(d) Handguard Assembly

The SIG handguard assembly is comprised of the one piece handguard and clamping hardware. The handguard features multiple M-LOK points for mounting accessories.

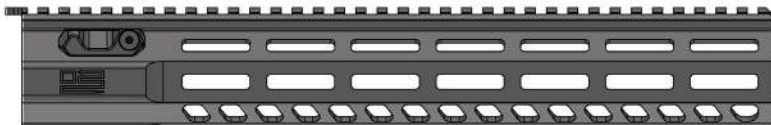



2.4.2 Lower Receiver Group

The Lower Receiver Group consists of the following assemblies: Lower Receiver Assembly with Fire Control Components, Buttstock Assembly, and Grip Assembly.



2.5 Cycle of Function

There are eight steps in the cycle of operation of the SIG716 TREAD which begin after a loaded magazine is inserted into the firearm.

FEEDING

As the bolt carrier is released from its rearward position, the carrier group moves forward allowing the lower lugs of the bolt to make contact with the rear of the cartridge as it sits in the magazine.

The cartridge is stripped from the magazine and begins its forward movement toward the chamber.

CHAMBERING

As the bolt moves forward the bolt locking lugs move forward into the barrel extension. The ejectors are then compressed against the left side of the cartridge head.

The last action that occurs is the extractor snapping over the rim of the cartridge case.



2.4 Cycle of Function- Continued

LOCKING

The movement of the bolt and the cartridge is stopped by the chamber.

The bolt carrier continues to move forward until it is stopped by contact with the rear face of the barrel extension.

As the carrier goes through the last portion of movement, the bolt is rotated to the left, through the action of the cam slot in the carrier and the cam pin through the bolt.

This engages the bolt lugs with the barrel extension lugs to lock the bolt into the barrel extension.

FIRING

The safety selector lever is rotated to the Semi-Auto position.

The trigger is pressed and the hammer is released. The hammer spring drives the hammer forward striking the firing pin. The firing pin strikes the cartridge primer, causing detonation.

UNLOCKING

As the bullet passes the gas port in the barrel, a small amount of gas is bled off, traveling up through the gas port and into the gas block. The gas travels through the gas tube to the carrier key of the bolt carrier. This gas then begins the rearward movement of the bolt carrier causing the cam pin to rotate the bolt to the unlocked position.

EXTRACTION

As the bolt carrier assembly moves rearward the spent case is pulled free from the chamber by the extractor. The twisting motion of the bolt aids in the extraction from the chamber.

EJECTION

The extractor continues to grip the rim of the spent case on the right side. The ejectors are applying forward pressure to the left side of the case. As the expended case clears the chamber, then the barrel extension, it is flipped out through the ejector port on the right side of the receiver.

COCKING

The rearward movement of the bolt carrier overrides the hammer, forcing it down into the receiver and compressing the hammer spring, cocking the hammer in the firing position.



3.0 Operating the SIG716 TREAD

3.1 Preparation before using the firearm.

Ensure you have read, understand, and are capable of following all the safety warnings on pages 2-19 of this manual in addition to the safety rules, regulations, procedures or guidelines of your club or local shooting range.

Prior to using the firearm it is strongly suggested to field strip the firearm (Section 4.0) and clean any fouling that might have occurred during factory testing (Section 5.0). Inspect, lubricate, and re-assemble the firearm (Section 6.0). Upon re-assembly and prior to firing the rifle, conduct the Function Check (Section 7.0).

Any maintenance beyond the user level described in this manual is to be performed by a professional gunsmith or certified SIG SAUER Armorer specifically trained on the maintenance of the SIG716 TREAD in accordance with the SIG SAUER 716 Technical Manual.

3.2 Selecting Modes of Fire

The SIG716 TREAD is configured as a semi automatic rifle. Modes of fire are selected by rotating the safety selector lever to the desired position. The SAFE position prevents the firearm from firing by blocking the action of the trigger. The SEMI position is for the semi-automatic mode and allows the firing of one round each time the trigger is pressed. The safety selector lever can only be rotated to SAFE when the hammer is cocked.

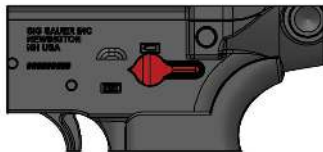

SAFE

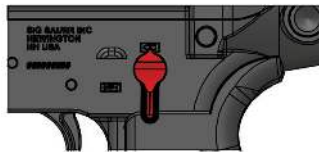

SEMI



3.3 Loading / Reloading

3.3.1 Loading the magazine

1. Ensure magazine is the proper type and caliber for the rifle.
2. Place a cartridge between the feed lips and press down. Ensure bullet is facing front of magazine.
3. Place another cartridge between the top of the previous cartridge and the feed lip and press down. Repeat Step 2. **DO NOT OVERLOAD THE MAGAZINE.**
4. Ensure the cartridges are fully seated to rear of magazine by tapping the back of magazine in the palm of the hand.



3.3.2 Clear the SIG716 TREAD prior to loading

1. Ensure the muzzle of the rifle is pointed in a safe direction at all times while unloading and clearing the firearm.
2. Press the magazine catch button on the right side or the ambi magazine catch on the left side to remove the magazine from the rifle.





3.3.2 Clear the SIG716 TREAD prior to loading - Continued

3. Lock the bolt carrier assembly to the rear by pressing and holding bottom portion of the bolt catch while pulling the charging handle fully rearward. Observe the ejection port on the right side for any ejected live rounds or expended cartridge cases. Ensure the bolt carrier assembly remains locked to the rear and return the charging handle to its forward and locked position. Rotate the safety selector lever to **SAFE**.



WARNING PARTS UNDER SPRING PRESSURE

THE BOLT CARRIER ASSEMBLY IS UNDER SPRING TENSION AND WILL SPRING FORWARD IF THE BOLT CATCH IS INADVERTENTLY DEPRESSED POSSIBLY CAUSING INJURY. DO NOT TO ALLOW THE BOLT CATCH TO BE PRESSED. THE CHAMBER OF THE RIFLE COULD POTENTIALLY BE HOT CAUSING BURNS. WHEN PHYSICALLY INSPECTING THE CHAMBER, USE A PEN OR SIMILAR OBJECT IF YOU ARE NOT SURE THE CHAMBER IS COLD.

4. Visually and physically inspect the chamber, bolt face and magazine well to ensure that there are no live rounds, spent cartridges or any foreign objects present.



5. If passing the rifle to another person, allow them to inspect the chamber before handling the firearm. Pass the rifle with the bolt locked to the rear and the safety selector lever on **SAFE**.



3.3.3 Loading rifle/ Bolt locked to the rear

1. Lock bolt carrier to rear by pressing inward on the bottom of the bolt catch as you pull the charging handle fully rearward.
2. Return the charging handle to the forward locked position.
3. Rotate the safety selector lever to the SAFE position.
4. Visually and physically inspect the chamber, bolt face and magazine well to ensure it is clear of ammunition.
5. Insert a loaded magazine until it engages and is held by the magazine catch. Always pull down to ensure the magazine is seated properly.
6. Press the top of the bolt catch inward releasing the bolt carrier. If the firearm is not to be fired immediately close the ejection port cover.



WARNING RIFLE IS NOW LOADED



3.3.4 Loading rifle / Bolt forward

1. Insert a loaded magazine until it engages and is held by the magazine catch. Always pull down to ensure the magazine is locked in place.
2. Pull the charging handle completely to the rear.
3. Release the charging handle allowing it to go forward under full spring pressure. (DO NOT RIDE IT FORWARD).
4. Rotate the safety selector lever to SAFE.



WARNING RIFLE IS NOW LOADED



3.4.4 Reloading rifle (Expended magazine/Bolt locked to the rear)

1. Rotate the safety selector lever to SAFE.
2. Press the magazine catch from either the left or right side. The empty magazine should fall free from the magazine well.
3. Insert a loaded magazine until it engages and is held by the magazine catch. Pull down to ensure the magazine is seated properly.
4. Press the top of the bolt catch releasing the bolt carrier forward to chamber a live cartridge.



WARNING RIFLE IS NOW LOADED





3.4.5 Reloading rifle (Partially expended magazine bolt forward, live round chambered)

1. Rotate the fire control selector to SAFE.
2. Grasp the magazine with the support hand and press the magazine catch from either the left or right side.
3. Remove the partially loaded magazine and secure it.
4. Insert a loaded magazine until it engages and is held by the magazine catch. Pull down to ensure the magazine is seated properly.



WARNING RIFLE IS NOW LOADED



3.5 Firing

SEMI: When the safety selector is rotated to this position, one press of the trigger will result in a single round being fired. You must release the trigger for it to reset.

To fire the SIG716 TREAD:

1. Adjust the buttstock if not already done.
2. Keep the muzzle pointed in a safe direction and insert a loaded magazine into the rifle.
3. Pull the charging handle completely rearward and release to chamber a cartridge.
4. Rotate the safety selector lever to SAFE.
5. Facing the target, placing the firearm to your shoulder.
6. Rotate the safety selector lever to SEMI.
7. Press the trigger to fire the cartridge.



3.6 Adverse/Special Environmental Conditions

Desert (Hot /Dry)

- Apply light lubrication to internal metal on metal moving parts only. If available, use dry graphite lubricant.
- Increase frequency of inspection and cleaning of firearm due to blowing dust and sand. Use muzzle covers if available.
- Unload and clean ammunition and inside of magazines daily. Do not lube magazine.
- Cover firearm when not in use.
- Close the ejection port cover when not in use.

Arctic (Extreme Cold/Sub Freezing)

- When operating in sub-freezing temperatures lubricate with a lubricant designed for use in this type of climate. Do not use CLP as it can prevent the firearm from firing. Ensure all existing lubricants are thoroughly removed prior to applying new lubricant.
- Avoid bringing firearm into heated shelters or buildings to prevent condensation from forming on moving parts which will freeze when the firearm is brought back outdoors.
- If necessary to bring the firearm indoors allow it to warm to room temperature then disassemble and clean thoroughly ensuring all moisture is removed from firearm then re-lubricate.
- When operating in snowy environments conduct frequent inspection of the firearm to ensure snow has not gotten into operating parts. Work the action to ensure it is not frozen. Use muzzle covers if available.
- If the bolt carrier becomes frozen with snow/moisture DO NOT discharge the firearm to free the bolt carrier. Warm firearm with body heat or bring indoors until free movement is restored then clean and re-lubricate the firearm.

Jungle (Hot /Humid)

- Increase frequency of inspection and cleaning of the firearm for rust / corrosion.
- Apply a light coat of lubricant to steel parts frequently.
- Inspect hidden surfaces of bolt carrier assembly, upper receiver, chamber and barrel extension.
- Inspect the lower receiver for corrosion.
- Inspect and lubricate the spring-loaded detents of the firearm.
- Unload magazine, clean ammunition, and inspect the inside of magazines daily for corrosion.
- Wipe ammunition dry before reloading.



3.7 Buttstock

The buttstock on the SIG716 TREAD provides for easy adjustment of the length to accommodate the individual shooter or for storage.

3.7.1 Adjusting the Stock

To adjust the position of the butt stock, press upward on the stock latch and hold. This will allow you to move the stock to the desired position.

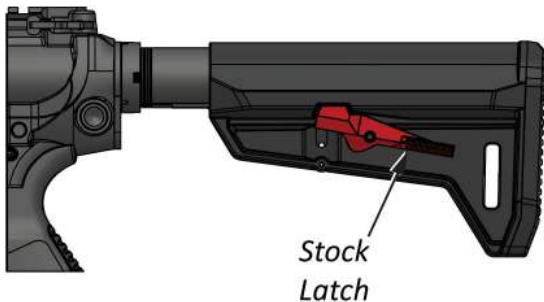

4.0 User Level Authorized Preventive Maintenance

4.1 Field Strip the SIG716 TREAD

1. Unload/Clear rifle of all ammunition.
2. Remove sling if attached.
3. Push takedown pin from left to right.





4.1 Field Strip the SIG716 TREAD - Continued

4. Swing receivers apart.
5. Partially retract charging handle and remove bolt carrier assembly.

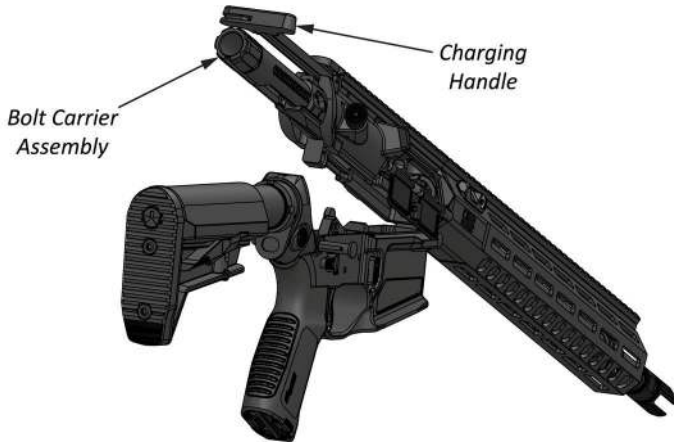

6. Remove charging handle.
7. Close receivers and push pivot pin from left to right.



8. Separate receivers.





4.2 Detailed Disassembly of Bolt Carrier Assembly

1. Remove firing pin retaining pin (1).
2. Remove firing pin (2) from rear of bolt.
3. Push bolt inward and remove cam pin (3) from bolt carrier.
4. Remove bolt (4) from bolt carrier (5).

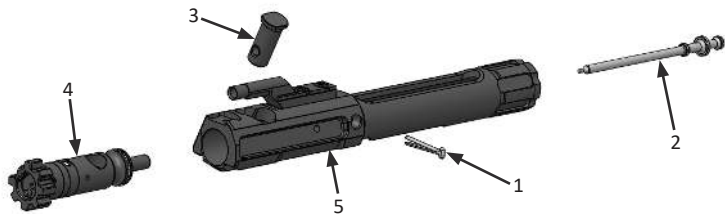

4.2.1 Disassembly of Bolt

1. Push extractor pin (2) to remove from either side of bolt.
2. Remove extractor (1).



CAUTION

NO FURTHER DISASSEMBLY OF THE EXTRACTOR COMPONENTS IS AUTHORIZED AT THIS LEVEL OF MAINTENANCE. DO NOT REMOVE THE EXTRACTOR SPRING. FAILURE TO COMPLY MAY RESULT IN DAMAGE TO COMPONENTS.



4.3 Removal of Buffer and Action Spring



WARNING PARTS UNDER SPRING PRESSURE



BUFFER IS UNDER PRESSURE FROM RECOIL SPRING. WEAR EYE PROTECTION. FAILURE TO COMPLY MAY RESULT IN INJURY.

1. Place thumb over front of buffer and press buffer retainer (1).
2. Release pressure on front of buffer and allow action spring (3) to push buffer (2) from receiver extension.
3. Use clockwise twisting motion to remove spring from buffer.

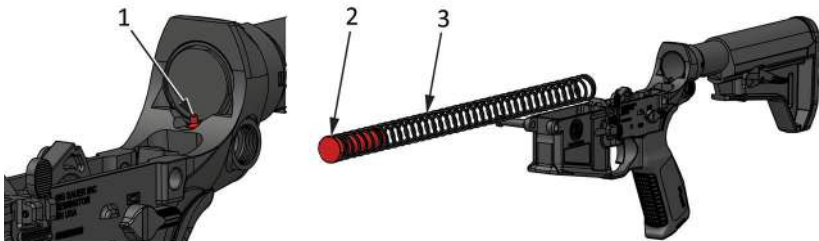

4.4 Disassemble Magazine

1. Push insert (3) inward and slide baseplate (2) from magazine tube (1).
2. Remove insert, magazine spring (5), and follower (4) from magazine tube (1).

NOTE

The magazine spring will be attached to the insert and follower. Do NOT remove the spring from these two components during operator level maintenance.

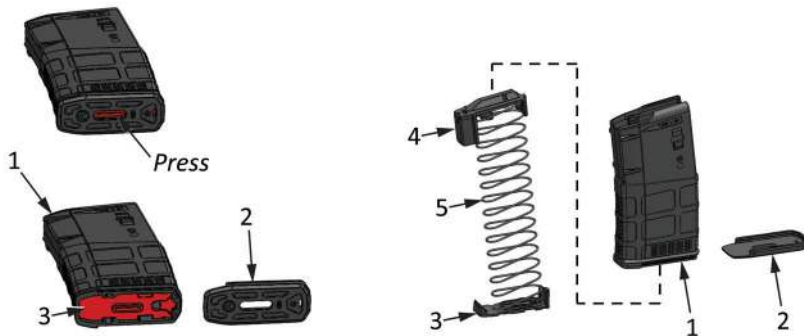



5.0 Cleaning/Lubrication

- Use only cleaning and lubrication products specifically designed for firearms.
- Do not use wire brushes on aluminum surfaces such as the upper and lower receivers. This may damage the finish.
- Follow all manufacturers instructions and cautions when using cleaning and lubrication products.
- Wherever the term CLP (Cleaner-Lubricant-Preservative) or the words lube or lubricant are used in this manual, it is interpreted to mean that any lubricant designed for firearms can be utilized as applicable.

5.1 Cleaning Chamber and Bore of Barrel

1. Attach a .30 caliber jag to the cleaning rod.
2. Attach a clean patch to the jag.
3. Moisten the patch with CLP and slowly push it through the bore toward the muzzle end.
4. Allow the CLP to stay in the barrel for several minutes to loosen any fouling.
5. Attach a new clean patch to the cleaning rod.
6. Coat the patch as before and push it through the bore
7. If heavy fouling is present, use a bore brush to scrub the bore.
8. Push a patch through the bore with CLP to remove any residue loosened by the bore brush.
9. Push new patches through the bore until they come out clean.
10. Coat the chamber brush with CLP.
11. Keep the muzzle elevated so the CLP does not run into the freshly cleaned bore.
12. Make several plunging strokes followed by several 360 degree rotations in the barrel extension to clean the locking lug area.

5.2 Cleaning Bolt Carrier Assembly

NOTE

Carbon residue must be scraped from the component. Use of a brush will not remove carbon build up.

1. Clean all residue from parts with a rag moistened with CLP.
2. Clean carbon build up from back of bolt.
3. Clean any carbon build up from hook end of extractor
4. Clean extractor slot in bolt.

5.3 Cleaning Upper/Lower Receivers

1. Clean all residue from receivers with a rag moistened with CLP.
2. Use cotton swabs for hard to reach areas.
3. Clean all residue from buffer and action spring with a rag moistened with CLP.



5.4 Lubrication

5.4.1 Bolt Carrier Assembly

CAUTION

DO NOT INTRODUCE LUBRICANT INTO THE TAILSHAFT OR FIRING PIN CHANNEL OF BOLT. DO NOT APPLY LUBRICANT TO EXTRACTOR SLOT. FAILURE TO COMPLY MAY RESULT IN A STOPPAGE.

1. Apply CLP to back of bolt lugs.
2. Lightly lubricate bolt body contact surfaces.
3. Lightly lubricate cam pin.
4. Lubricate contact surfaces of bolt carrier.

5.4.2 Action Spring

1. Lightly lubricate the action spring with CLP.

5.4.3 Upper/Lower Receivers

1. Lightly lubricate charging handle.
2. Apply CLP to ejection port cover spring and latch.
3. Apply CLP to the detent slots in the takedown and pivot pins.
4. Apply CLP with a cotton swab to hammer and trigger springs.
5. Apply CLP to fire control selector.



6.0 Assembly

6.1 Assemble Magazine



WARNING PARTS UNDER SPRING PRESSURE



MAGAZINE SPRING WILL BE UNDER PRESSURE DURING ASSEMBLY. WEAR EYE PROTECTION AND USE CAUTION WHEN COMPRESSING SPRING. FAILURE TO COMPLY MAY RESULT IN INJURY.

1. Install follower, spring, and insert into magazine tube.
2. Compress spring by pushing insert into magazine tube.
3. Slide base plate on to magazine tube until insert snaps into place.

6.2 Recoil Buffer and Action Spring

1. Slide action spring over recoil buffer and snap into place with a clockwise twisting motion as you press spring forward.
2. Insert action spring into receiver extension. Hammer should be cocked and rifle on SAFE to ease installation.

3. Push recoil buffer into receiver extension until it snaps behind buffer retaining plunger.

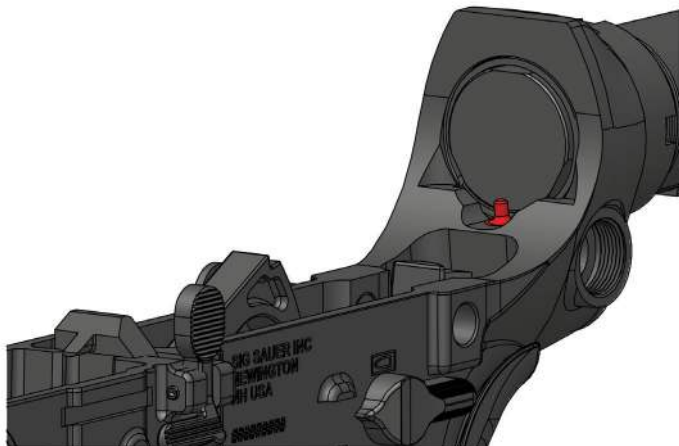



6.3 Assemble Bolt Carrier Group

1. Assemble extractor to bolt body.



2. Insert bolt into bolt carrier with extractor facing right side of carrier.



**WARNING MALFUNCTION**

ENSURE CAM PIN AND FIRING PIN ARE INSTALLED CORRECTLY. FAILURE TO COMPLY MAY RESULT IN INJURY OR DEATH TO USER AND CATASTROPHIC DAMAGE TO THE FIREARM.

3. Install cam pin through bolt carrier and into bolt body.

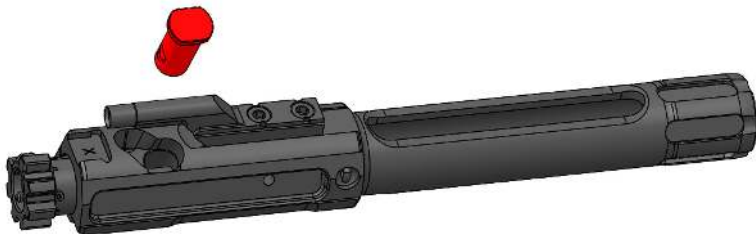



6.3 Assemble Bolt Carrier Group- Continued

4. Pull bolt out to unlocked position. Insert firing pin through rear of bolt and seat firing pin completely forward against bolt.
5. Insert firing pin retaining pin from the left side of bolt carrier. Ensure the retaining pin is positioned between the head of the firing pin and the large flange.

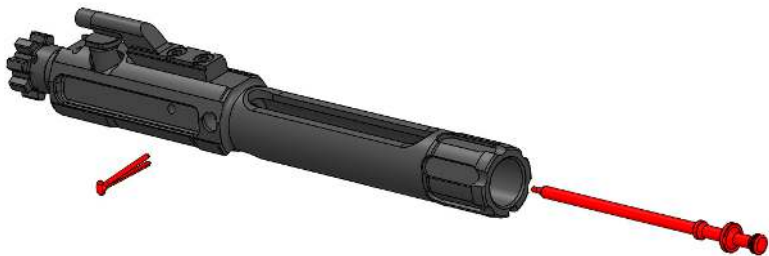

NOTE

Firing pin should not fall out when bolt carrier assembly is turned upside down.

6.4 Final Assembly

1. Partially insert charging handle into upper receiver.
2. Pull bolt forward to unlocked position and insert bolt carrier group into upper receiver.
3. Push bolt carrier group and charging handle completely forward until the bolt locks into the barrel extension. Ensure charging handle is locked to upper receiver.





6.4 Final Assembly - Continued

4. Align upper receiver to lower receiver and push pivot pin in from right to left.



5. Close receivers together and push takedown pin from right to left .



7.0 Function Check

1. Ensure firearm is unloaded and clear of ammunition (Section 3.3).
2. Insert an unloaded magazine into magazine well.
3. Pull charging handle to rear until bolt locks open. Lock charging handle forward.
4. Rotate fire control selector to **SAFE**.
5. Press magazine catch. Magazine should fall free of magazine well.
6. Pull charging handle to rear and release. Bolt catch must drop and release bolt forward.
7. Press trigger to rear. Hammer should not fall.
8. Rotate the safety selector lever to **SEMI**.
9. Press and **hold** trigger to rear. Hammer should fall.
10. Fully retract charging handle/bolt carrier assembly cocking the firearm. Lock charging handle forward.
11. Slowly release the trigger. You should hear an audible click.
12. Press trigger, hammer should fall.



8.0 Trouble Shooting

STOPPAGE	CAUSE	CORRECTIVE ACTION
Fails to Fire	Selector on SAFE	Rotate to a SEMI position
	Firing pin improperly installed	Correct assembly
	Excessive lubricant in firing pin recess of bolt	Clean/Reassemble
	Defective ammunition	Replace ammunition
Failure to Feed	Defective magazine	Replace magazine
	Overloaded magazine	Remove excess cartridges
	Dirty/Corroded ammunition	Replace ammunition
Fail to Chamber	Poor lubrication/ Dirty firearm	Clean and lube
	Dirty/Corroded/Damaged ammunition	Replace ammunition
	Dirty chamber	Clean chamber/barrel
	Poor lubrication/ Dirty firearm	Clean and lube
	Weak action spring	Replace spring

STOPPAGE	CAUSE	CORRECTIVE ACTION
Double Feed	Defective magazine	Replace magazine
Bolt Fails to Lock	Dirty bolt/Poor lubrication	Clean and lube
	Damaged bolt lugs	Contact customer service
Failure to Extract	Frozen extractor	Clean and replace
	Broken extractor spring	Contact customer service
	Restricted movement of bolt carrier	Clean, lube, replace
Fail to Lock After Last Round Fired	Dirty chamber	Clean chamber and bore
	Defective magazine	Replace magazine
Under Function	Broken bolt catch	Contact customer service
	Damaged/worn gas rings	Contact customer service
Frozen Fire Control Selector	Carrier key dirty or plugged	Clean carrier key
	Lack of lubricant	Lube selector
	Dirt/Residue build up beneath selector	Clean rifle



9.0 Storage



WARNING

UNLOAD/CLEAR



PRIOR TO STORING THE 716, BE SURE TO UNLOAD AND CLEAR THE FIREARM OF ALL AMMUNITION BY CONDUCTING BOTH A VISUAL AND PHYSICAL INSPECTION OF THE CHAMBER TO ENSURE NO AMMUNITION IS PRESENT. FAILURE TO COMPLY COULD RESULT IN INJURY OR DEATH OR DAMAGE TO PROPERTY.

Short Term Storage (90 days or less).

1. Ensure the chamber and magazine do not contain live ammunition.
2. Clean the bore and chamber.
3. Apply a medium coat of CLP to the chamber and bore.
4. Apply a light coat of CLP to all other metal surfaces for corrosion protection.
5. Do not attempt to store a rifle that is hot after firing.
6. Adjust the buttstock to its shortest length to reduce the chances of damage.

Long Term Storage (90 days or longer).

1. Ensure the rifle is thoroughly cleaned.
2. Apply a medium coat of CLP to the chamber and bore.
3. Adjust the buttstock to its shortest length to reduce the chances of damage if applicable.
4. Apply a light coat of CLP to all other metal surfaces for corrosion protection.
5. Wrap the firearm with a waterproof material (MIL-B-121 or similar).
6. Place the firearm in a corrosion resistant barrier bag (MIL-DTL-117 or similar).

Environmental Storage Recommendations (Armory)

Provide humidity control to limit the relative humidity (RH) to no greater than 40% at 80°F (26.7°C). If personnel will be working in these areas, design to 68°F (20.0°C) dry bulb and 40% RH for indoor design heating conditions, and 75°F (23.9°C) dry bulb and 40% RH for indoor design cooling conditions.



10.0 Parts Diagrams

10.1 Upper Receiver Assembly Parts Diagram

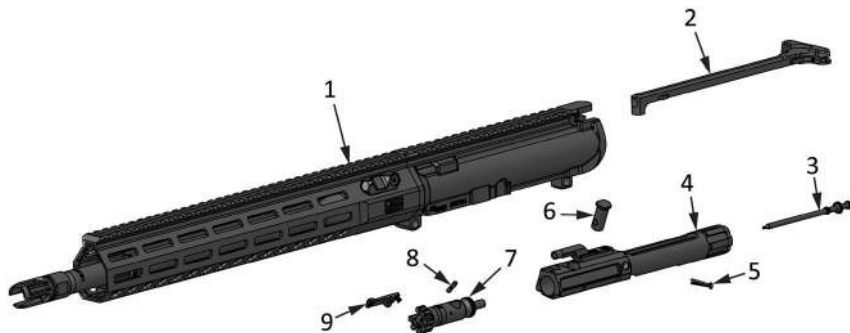

10.2 Upper Receiver Assembly Parts List

- | | | |
|-----------------------------|-----------------------------|------------------|
| 1. Upper Receiver | 4. Bolt Carrier | 7. Bolt |
| 2. Charging Handle Assembly | 5. Firing Pin Retaining Pin | 8. Extractor Pin |
| 3. Firing Pin | 6. Cam Pin | 9. Extractor |



10.3 Lower Receiver Assembly Parts Diagram

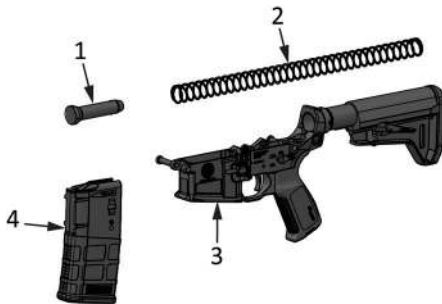

10.4 Lower Receiver Assembly Parts List

- | | |
|--------------------|---|
| 1. Buffer Assembly | 3. Lower Receiver Assembly with Buttstock |
| 2. Action Spring | 4. Magazine |

11.0 Service and Replacement Parts Policy



WARNING

IT IS THE PURCHASER'S RESPONSIBILITY TO BE ABSOLUTELY CERTAIN THAT ANY PARTS ORDERED FROM THE FACTORY ARE CORRECTLY FITTED AND INSTALLED. FIREARMS ARE COMPLICATED MECHANISMS AND IMPROPER FITTING OF PARTS MAY RESULT IN A DANGEROUS MALFUNCTION, DAMAGE TO THE FIREARM, AND SERIOUS INJURY TO THE SHOOTER AND OTHER PERSONS. THE PURCHASER AND INSTALLER OF PARTS MUST ACCEPT FULL RESPONSIBILITY FOR THE CORRECT ADJUSTMENT AND FUNCTIONING OF THE FIREARM AFTER SUCH INSTALLATION.

Parts Policy

Our Service Department maintains a full complement of replacement parts. Even though most gunsmiths have the knowledge, training, and the ability to make necessary repairs to your firearm, the skill and workmanship of any particular third-party gunsmith is totally beyond our control.

Should your firearm ever require service, we strongly recommend that you return it to SIG SAUER Inc. A firearm is a precision instrument and some replacement parts will require individual fitting to ensure correct operation. A wrong part, improper fitting, or incorrect mechanical adjustment may result in an unsafe condition or dangerous malfunction, damage to the firearm, or cause possible serious injury to the shooter or others



Parts Policy - Continued

IF ANY PART IS ORDERED WITHOUT RETURNING THE FIREARM TO SIG SAUER Inc., the customer bears full responsibility for ensuring that the part supplied is correct for their particular firearm and is properly installed and fitted by a qualified gunsmith.

SIG SAUER INC. IS NOT RESPONSIBLE FOR THE FUNCTIONING OF ANY FIREARM IN WHICH REPLACEMENT PARTS ARE INSTALLED BY OTHERS.

THE USE OF AFTERMARKET PARTS IS NOT AUTHORIZED AND WILL VOID THE WARRANTY OF THIS FIREARM. THE REPLACEMENT OF ORIGINAL EQUIPMENT MANUFACTURER (OEM) SIG SAUER CROSS PARTS WITH THESE PARTS IS UNAUTHORIZED, AND IN SOME INSTANCES COULD ALTER THE FUNCTION OF THE CROSS, CREATING A DANGER TO THE OPERATOR OF THIS FIREARM.

Service Policy

If you have questions concerning the performance or servicing of your firearm, please write or call:

SIG SAUER Inc.
Attention Customer Service
72 Pease Boulevard, Newington, NH 03801
Phone: (603) 610-3000 Ext. 1
Fax: (603) 766-7002

IF YOU DO NOT UNDERSTAND THE INSTRUCTIONS FOR OPERATING YOUR FIREARM, IT IS YOUR RESPONSIBILITY TO CALL OUR CUSTOMER SERVICE DEPARTMENT AT (603) 610-3000 Ext. 1 BEFORE USING YOUR FIREARM.

12.0 Shipping Firearms for Repair



WARNING DO NOT SHIP AMMUNITION



BEFORE SHIPPING ANY FIREARM, BE ABSOLUTELY CERTAIN THAT THE FIREARM AND ITS MAGAZINE ARE UNLOADED. DO NOT SHIP AMMUNITION WITH A FIREARM.

In the event that you need to return your firearm to the SIG SAUER Service Department, here's what to do:

1. Contact Customer Service at (603) 610-3000 for a return merchandise authorization (RMA) number. This number allows SIG SAUER to track the status of your return from its receipt at SIG SAUER through its return to you. Please do not send your firearm until you obtain an RMA number.
2. Ensure that the chamber and magazine(s) are unloaded and that no ammunition is included with your returned firearm.
3. Package the firearm securely to prevent damage. Enclose a letter that includes your name, street address, daytime phone number, model and serial number, and a detailed description of the problem you have experienced or the work that you want performed. With the exception of extra magazines, do not include any other accessories such as scopes or mounts.



4. Generally, an individual may ship firearms to the manufacturer for repair or service. Some states and localities, however, prohibit this. If you live in such an area, the firearms must be shipped by and returned to a federally licensed firearms dealer.
5. Federal law prohibits persons who do not possess a Federal Firearms License (FFL) from shipping a firearm via the U.S. Postal Service. (Note: any shipment of firearms outside U.S. borders is subject to the export laws of the United States and to the valid laws of the specific country, which you must strictly follow; prior to exporting any firearm you should seek legal counsel.)
6. SIG SAUER is not responsible for any firearm until it is received, nor for damage incurred during shipment.
7. Ship your firearms insured and prepaid (we do not accept collect shipments) to:

SIG SAUER, Inc.
Attention: Service Department
18 Industrial Drive Exeter, NH 03833

Don't forget to write your RMA number on the package.

A copy of this instruction manual should always accompany this firearm and be transferred with it upon change of ownership.

Order Parts

In the event that you want to order parts for your SIG firearm, contact Customer Service at (603) 610-3000 Ext.

1. Have available the serial number of your firearm and the part diagram number for the part(s) you wish to order. A parts list and diagram of the firearm is provided in this manual.



SIG SAUER® Limited Lifetime Firearms Warranty

SIG SAUER warrants that the enclosed firearm was originally manufactured free of defects in material, workmanship, and mechanical function. For the lifetime of the original purchaser, SIG SAUER agrees to correct any defect in the firearm for the original purchaser by repair, adjustment, or replacement, at SIG SAUER's option, with the same or comparable quality components (or by replacing the firearm at SIG SAUER's option); provided however that a Return Merchandise Authorization (RMA) is first obtained by contacting SIG SAUER Customer Service, and the firearm is returned unloaded and freight prepaid to:

SIG SAUER
18 Industrial Drive
Exeter, NH 03833

This limited warranty is null and void if the firearm has been misused, damaged (by accident or otherwise), fired with handloaded, reloaded, or improper ammunition, fired with an obstruction in the barrel, damaged through failure to provide reasonable and necessary maintenance as described in the manual accompanying the firearm, or if unauthorized repair or any alteration, including of a cosmetic nature, has been performed on the firearm. This limited warranty does not apply to normal wear and tear of any parts.

Subject to the foregoing, this limited warranty confers the right to have the covered firearm or its parts repaired, adjusted, or replaced exclusively upon the original purchaser, which right is not transferable to any other person. This warranty does not apply to any accessory items attached or appurtenant to the firearm.

ANY WARRANTIES IMPLIED BY LAW, INCLUDING ANY IMPLIED WARRANTIES OF MERCHANTABILITY OR FITNESS FOR A PARTICULAR PURPOSE, ARE EXPRESSLY DISCLAIMED. REPAIR, ALTERATION, OR REPLACEMENT AS PROVIDED HEREIN IS YOUR EXCLUSIVE REMEDY FOR ANY DEFECTIVE PRODUCT. IN NO EVENT SHALL SIG SAUER OR ANY COMPANY AFFILIATED WITH SIG SAUER BE LIABLE FOR ANY SPECIAL, INCIDENTAL, OR CONSEQUENTIAL DAMAGES OF ANY KIND ARISING OUT OF THE PURCHASE OR USE OF THIS PRODUCT, WHETHER BASED UPON

CONTRACT, TORT, STATUTE, OR OTHERWISE. Some states do not allow the exclusion or limitation of implied warranties, or the exclusion or limitation of incidental or consequential damages, so some or all of the above limitations or exclusions may not apply to you. This warranty gives you specific legal rights, and you may also have other rights which vary from State to State.

THIS WARRANTY APPLIES TO U.S. COMMERCIAL CUSTOMERS ONLY, AND DOES NOT APPLY TO GOVERNMENT, MILITARY, LAW ENFORCEMENT, OR NON-US CUSTOMERS. NON-US CUSTOMERS SHOULD CONTACT THEIR LOCAL DEALER OR DISTRIBUTOR FOR APPLICABLE WARRANTY COVERAGE.



www.sigsauer.com

72 Pease Boulevard, Newington, NH 03801 USA

All trademarks, service marks, trade names, trade dress, product names and logos appearing in this manual are the property of their respective owners. No trademark or service mark appearing in this manual may be used without written consent of the mark's owner.

©2021 SIG SAUER, Inc. All rights reserved.

AN ISO 9001 REGISTERED COMPANY

P/N 1801325-01 REV 03