



Smith & Wesson®

Safety & Instruction Manual Centerfire Semi-Automatic Rifles

INCLUDING

VOLUNTEER SERIES™ & SPORT SERIES™



M&P 10



M&P 15



**Read the instructions and
warnings in this manual
CAREFULLY BEFORE
using this firearm.**

2100 Roosevelt Avenue • Springfield, MA 01104

1-800-331-0852 • Fax: 1-413-747-3317

www.smith-wesson.com

Copyright © 2022 Smith & Wesson Inc.
All rights reserved.



WARNING:



**READ THESE INSTRUCTIONS
AND WARNINGS CAREFULLY.
BE SURE YOU UNDERSTAND THESE
INSTRUCTIONS AND WARNINGS BEFORE
USING THIS FIREARM. FAILURE TO READ THESE
INSTRUCTIONS AND FOLLOW THESE
WARNINGS MAY RESULT IN SERIOUS INJURY
OR DEATH TO YOU AND OTHERS AND
DAMAGE TO PROPERTY.**

**THIS SAFETY & INSTRUCTION
MANUAL SHOULD ALWAYS
ACCOMPANY THIS FIREARM AND BE
TRANSFERRED WITH IT UPON CHANGE OF
OWNERSHIP OR WHEN PRESENTED TO ANOTHER
PERSON. A COPY OF THE SAFETY & INSTRUCTION
MANUAL IS AVAILABLE FREE VIA DOWNLOAD AT
WWW.SMITH-WESSON.COM
OR UPON REQUEST FROM:**

**SMITH & WESSON®
CUSTOMER SUPPORT CENTER
2100 ROOSEVELT AVENUE
SPRINGFIELD, MA 01104
TEL.: 1-800-331-0852, ext. 4125
E-mail: qa@smith-wesson.com**

NOTE: The M&P® SPORT™ Series and S&W® VOLUNTEER™ Series of rifles, as sold by Smith & Wesson®, are classified as rifles. Changes to the configuration of these rifles by the end-user, including but not limited to, the addition of a barrel less than 16" in length will subject the firearm to classification under the National Firearms Act, which imposes registration, taxes, and other requirements on the owners of such firearms. It is your responsibility to comply with all Federal, State and Local Laws and regulations regarding the ownership or possession of this firearm and any conversions or additions of any after-market accessories that you undertake.

TABLE OF CONTENTS

YOUR SAFETY RESPONSIBILITIES	3-6
SAFE STORAGE AND TRANSPORTATION	7-8
AMMUNITION	9-11
MODEL AND FEATURES IDENTIFICATION.....	12-15
INSPECTING YOUR FIREARM.....	16-17
PREPARATION FOR FIRING	18
LOADING	19-22
FIRING.....	23
HANGFIRES AND MISFIRES.....	24-25
CLEARING A MISFEED/JAM.....	26-27
UNLOADING	27-28
DISASSEMBLY / FIELD STRIPPING	28-30
SPECIAL COMPONENT DISASSEMBLY	31-35
ASSEMBLY	36-37
COLLAPSIBLE STOCK (if rifle is so-equipped)	37
SIGHT ADJUSTMENT (if rifle is so-equipped)	38-40
INSTALLATION OF OPTICAL SIGHTS	41
MAGAZINE	42-43
CLEANING AND MAINTENANCE	44-46
LIMITED WARRANTY	47-48
CONTACT AND SHIPPING INFORMATION	49-50
CUSTOM SERVICE	51
ADDENDUM: M-LOK® ACCESSORY RAIL INFORMATION	52-57
BATTERY WARNINGS	58
PATENT INFORMATION	59

YOUR SAFETY RESPONSIBILITIES

SAFETY IS YOUR NUMBER ONE RESPONSIBILITY!

- At home, in the field, at the range, or anywhere, the first concern of every firearm owner should be safety. Apply the following safety rules in every situation, with any kind of firearm. If you feel uncertain about any operational aspects of your firearm, please contact Smith & Wesson at 1-800-331-0852, ext. 4125 before proceeding with its operation.
- If you are unfamiliar with firearms you should seek formal training before using your rifle.



WARNING: YOU MUST FOLLOW ALL OF THESE SAFETY RULES TO ENSURE THE SAFE USE OF YOUR FIREARM. THE FAILURE TO FOLLOW THE INSTRUCTIONS AND WARNINGS IN THIS MANUAL COULD CAUSE SERIOUS PERSONAL INJURY OR DEATH TO YOU OR OTHERS AND DAMAGE TO PROPERTY.

- As a firearm owner, you accept a demanding responsibility. How seriously you take this responsibility can be the difference between life and death. There is no excuse for careless or abusive handling of your firearm. At all times handle your firearm with intense respect for its power and potential danger.

YOUR SAFETY RESPONSIBILITIES CONTINUED

- **ALWAYS KEEP YOUR FIREARM POINTED IN A SAFE DIRECTION.** Never point a firearm at anyone or anything you do not intend to shoot whether or not it is loaded. This is particularly important when loading, unloading, or field stripping the firearm. ALWAYS control the direction of the firearm.
- **ALWAYS TREAT EVERY FIREARM AS IF IT IS LOADED AND WILL FIRE.** Do not take anyone's word that the firearm is unloaded – always check for yourself. Never pass your firearm to another person until the cylinder or action is open and you visually check that it is unloaded. Keep your firearm unloaded and safely stored when not in use.
- **NEVER PLACE YOUR FINGER INSIDE THE TRIGGER GUARD OR ON THE TRIGGER UNLESS YOU INTEND TO FIRE.** Ensure that other objects do not touch the trigger.
- **ALWAYS BE SURE OF YOUR TARGET AND WHAT IS BEYOND IT.** Always be sure of where the bullet will strike and shoot only where there is a safe back stop free of obstructions, water or other surfaces which can cause a ricochet. Be sure your bullet will stop behind your target. Bullets can glance off many surfaces like rocks or the surface of water and travel in unpredictable directions with considerable velocity. Do not fire randomly into the sky.
- **NEVER CROSS OBSTACLES SUCH AS FENCES OR STREAMS WITH A LOADED FIREARM.** Always make certain your firearm is unloaded before crossing a fence, climbing a tree, jumping a ditch or negotiating other obstacles.
- **SAFE FIREARM HANDLING IS YOUR PERSONAL RESPONSIBILITY AT ALL TIMES.** Firearms are dangerous and can cause serious injury or death if they are misused or used inappropriately. Safety must be the prime consideration of any one who owns or handles firearms. Accidents are the result of violating the rules of safe firearm handling and common sense. Firearm safety training is available. Contact your firearms dealer, law enforcement agency, local sportsman's club, etc. for availability.
- **YOU ARE RESPONSIBLE FOR THE FIREARM AT ALL TIMES.** In owning a firearm, you must undertake full-time responsibility for your firearm's safety and security. You must protect yourself and all others against injury or death from misuse of the firearm 24 hours a day.
- **FIREARM SECURITY IS YOUR RESPONSIBILITY.** You must secure firearms safely from children and/or unauthorized users. Your firearm should always be kept unloaded and locked when not in use. A lock has been provided for this purpose. Never assume that the use of this lock is sufficient to safely secure your firearm. You must always evaluate your personal situation and employ the security systems that meet your needs and prevent children and unauthorized users from gaining access to your firearm.

YOUR SAFETY RESPONSIBILITIES CONTINUED

- **APPROPRIATE USE FOR YOUR FIREARM MEANS USING YOUR FIREARM FOR LEGAL PURPOSES.** For example - target shooting, hunting and lawful resistance of deadly criminal force. It is your responsibility to ensure that you are in compliance with all applicable laws and ordinances regarding the use of your firearm.
- **NEVER RELY ON MECHANICAL FEATURES ALONE.** Only your safe firearm-handling habits will ensure the safe use of your firearm. This is your responsibility.
- **ALWAYS SAFELY STORE AND SECURE YOUR FIREARM.** Safe and secure storage of your firearm is one of your most important responsibilities. It is a full-time responsibility. You must always secure your firearm and ammunition separately so that they are not accessible to children and/or other unauthorized persons.
- **NEVER KEEP AMMUNITION IN THE SAME LOCATION AS THE FIREARM.** Store each in a separate and secure place.
- **ALWAYS WEAR EYE PROTECTION THAT IS SPECIFIED FOR USE WITH FIREARMS** every time you handle your firearm for cleaning and maintenance.
- **ALWAYS WEAR EYE AND HEARING PROTECTION THAT ARE SPECIFIED FOR USE WITH FIREARMS** every time you discharge your firearm. Make sure others in the vicinity of where you will be shooting do so as well.
- **NEVER USE ALCOHOL OR DRUGS BEFORE OR WHILE SHOOTING.** Do not use your firearm if you are on any medication which impairs, even slightly, your mental or physical ability.
- **ALWAYS HAVE ADEQUATE VENTILATION.** Discharging firearms in poorly ventilated areas, cleaning firearms, or handling ammunition may result in exposure to lead and other substances known to cause birth defects, reproductive harm, and other serious physical injury. Review the warnings and labels for all ammunition and cleaning products carefully. Wash hands thoroughly after exposure.
- **BEFORE HANDLING ANY FIREARM, UNDERSTAND ITS OPERATION.** Not all firearms are the same. Familiarize yourself with the mechanical features of any firearm you intend to use. If you feel uncertain about any operational aspects of your firearm, please contact Smith & Wesson at 1-800-331-0852, ext. 4125 before proceeding with its operation.
- **NEVER ALLOW A FIREARM TO BE USED BY INDIVIDUALS WHO DO NOT UNDERSTAND ITS SAFE OPERATION OR HAVE NOT READ THESE FIREARM SAFETY RULES.**

YOUR SAFETY RESPONSIBILITIES CONTINUED

- **ALWAYS USE THE CORRECT AMMUNITION FOR YOUR PARTICULAR FIREARM** as indicated by the marking on the firearm. Never use non-standard, reloaded, or “handloaded” ammunition which has not been subjected to internal ballistic pressure testing.
- **BEWARE OF BARREL OBSTRUCTIONS.** Be sure the barrel is clear of obstructions before shooting. Mud, water, snow or other objects may inadvertently lodge in the barrel bore. A small obstruction can cause a dangerous increase in pressure and may damage your firearm and cause injury to yourself and others.
- **BE SURE ALL ACCESSORIES, SUCH AS HOLSTERS, GRIPS, SLINGS, SCOPES AND OTHER ACCESSORIES ARE COMPATIBLE** with the firearm and that the accessories do not interfere with safe operation. It is your responsibility to understand and follow all of the instructions in this manual, as well as those which may be supplied with your ammunition and any accessory.
- **NEVER DISASSEMBLE YOUR FIREARM** beyond the field stripping procedure outlined in this manual. Improper disassembly or reassembly of your firearm may be dangerous and can lead to serious injury or death.
- **NEVER MANIPULATE, ADJUST OR CHANGE ANY OF THE INTERNAL COMPONENTS OF YOUR FIREARM UNLESS SPECIFICALLY INSTRUCTED TO DO SO IN THIS MANUAL.** Improper manipulation of any internal component may affect the safety and reliability of your firearm and may cause serious injury or death.
- **NEVER ALLOW ANY ALTERATION OR REPLACEMENT OF PARTS IN YOUR SMITH & WESSON FIREARM UNLESS PERFORMED BY A QUALIFIED GUNSMITH** using genuine Smith & Wesson parts. If you do otherwise, improper functioning of your firearm may occur and serious injury or death and damage to property may result.



WARNING: SAFE USE OF A FIREARM IS YOUR PERSONAL RESPONSIBILITY AND THE FAILURE TO FOLLOW ALL OF THESE BASIC SAFETY RULES MAY RESULT IN PERSONAL INJURY OR DEATH TO YOU OR OTHERS AND DAMAGE TO PROPERTY. YOU ARE THE MOST IMPORTANT SAFETY DEVICE WHEN IT COMES TO THE USE OF YOUR FIREARM AND SMITH & WESSON WILL NOT BE RESPONSIBLE FOR ANY PERSONAL INJURY, DEATH OR PROPERTY DAMAGE THAT RESULTS FROM: (1) THE CRIMINAL OR NEGLIGENT USE OF THIS FIREARM; (2) A DISREGARD OF THESE SAFETY INSTRUCTIONS AND WARNINGS; (3) IMPROPER OR CARELESS HANDLING OF THIS FIREARM; (4) THE USE OF NON-STANDARD, DEFECTIVE, OR IMPROPER AMMUNITION; (5) OR, IMPROPER OR NEGLIGENT MODIFICATIONS OR REPAIRS TO THE FIREARM.

SAFE STORAGE AND TRANSPORTATION



WARNING: ALWAYS POINT THE MUZZLE IN A SAFE DIRECTION.



WARNING: FIREARMS ARE DANGEROUS WHEN USED AND STORED IMPROPERLY. THEY POSE A RISK OF SERIOUS OR FATAL INJURIES. FIREARMS CAN BE ESPECIALLY DANGEROUS TO CHILDREN WHEN THEY ARE STORED IN AN IRRESPONSIBLE AND UNSAFE MANNER. FOR YOUR SAFETY AND THE SAFETY OF OTHERS, IT IS IMPERATIVE THAT YOU KEEP YOUR FIREARM LOCKED AND UNLOADED IN A SECURE PLACE. THE AMMUNITION SHOULD BE STORED IN A SEPARATE, SECURE LOCATION WHEN IT IS NOT IN USE. SAFE AND SECURE STORAGE OF YOUR FIREARM IS ONE OF THE MOST IMPORTANT RULES OF FIREARM SAFETY. YOUR FAILURE TO FOLLOW THESE RULES MAY RESULT IN SERIOUS INJURY OR DEATH TO YOU OR OTHERS.

- **ALWAYS SECURE YOUR FIREARM IN A MANNER THAT WILL PREVENT UNAUTHORIZED ACCESS.** Whenever your firearm is not in use, keep it unloaded and locked. Your safety and the safety of others requires that you always secure and store your firearm in a manner that will prevent unauthorized access. Never leave a firearm unattended unless it is locked, unloaded and secured.
- **ALWAYS USE THE LOCK PROVIDED BY SMITH & WESSON TO SECURE YOUR FIREARM.** Please read and follow the instructions packaged separately for the use of this lock. A lock, when properly used, can be an effective tool in preventing unauthorized access to your firearm. There are other alternative locks and safe storage containers available in the marketplace which may also be appropriate for your particular needs. Consult your local firearm shop, hardware store, or local police department for guidance on the variety of other safe storage devices or practices which may be appropriate for your particular needs. By purchasing this firearm you have accepted the responsibility of safely securing the firearm at all times and preventing its unauthorized use. Never assume that the use of this lock alone is sufficient to safely secure your firearm. It is your personal responsibility to select and use whatever measures or practices that will enable you to be absolutely certain that your firearm is secure at all times.



WARNING: NEVER LOCK A LOADED FIREARM.

SAFE STORAGE AND TRANSPORTATION CONT'D

- **ALWAYS STORE YOUR FIREARM AND AMMUNITION SEPARATELY** so that they are not accessible to children or other unauthorized persons. Safe and secure storage of your firearm and ammunition are your responsibility. It is a full-time responsibility.
- **NEVER ASSUME THAT A “HIDING” PLACE IS A SECURE STORAGE METHOD.** Others may be aware of your storage location or come upon it by chance. It is your personal responsibility to use common sense when storing your firearm and ammunition and to always make sure they are not accessible to children or other unauthorized persons.
- **NEVER TRANSPORT A LOADED FIREARM.** When transporting your firearm, be sure it is unloaded and locked. Safe and secure transportation of your firearm is your responsibility.
- **ALWAYS FOLLOW THE LAW!** Many jurisdictions have laws that make it a crime to keep a firearm unlocked and in an area accessible to children or others. Keeping a firearm locked and unloaded when not in use is not only common sense safety practice. IT IS THE LAW. You must be familiar with all local, state, and federal laws regarding the safe storage and transportation of your firearm. Failure to know and follow the law may result in unauthorized access or use of your firearm by another. Obey all laws relating to the storage and transportation of firearms. Your local police department or firearm shop can furnish you with available information on storing and/or transporting a firearm safely and legally.
- **YOUR FIREARM IS YOUR RESPONSIBILITY.** You must prevent your firearm from being stolen or from being used by untrained or unqualified individuals. Keep it locked, unloaded and secured when not in use.
- Never leave the key with the stored firearm.

AMMUNITION



WARNING: NEVER USE AMMUNITION NOT SPECIFICALLY DESIGNATED FOR USE IN YOUR FIREARM. FAILURE TO USE THE CORRECT TYPE OR CALIBER OF AMMUNITION MAY CAUSE THE FIREARM TO JAM, FAIL TO FIRE, OR MAY GENERATE EXCESSIVE PRESSURE WHICH CAN DAMAGE OR EVEN RUPTURE YOUR FIREARM, CAUSING PERSONAL INJURY OR DEATH TO THE SHOOTER OR BYSTANDERS.

- Locate the cartridge designation marked on the firearm's barrel. This information indicates the correct ammunition that must be used in your firearm (FIGURE 1).
- You are responsible for selecting ammunition that meets industry standards and is appropriate in type and caliber for this firearm.
- Never mix ammunition.

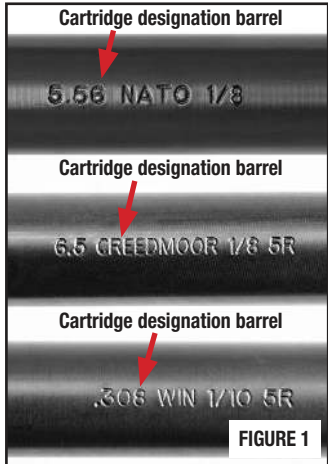

WARNING: NEVER USE AMMUNITION MARKED 5.56 NATO IN A FIREARM MARKED 223 REM. FAILURE TO ADHERE TO THIS WARNING MAY CAUSE EXCESSIVE PRESSURE WHICH CAN DAMAGE OR EVEN RUPTURE YOUR FIREARM, CAUSING PERSONAL INJURY OR DEATH TO THE SHOOTER OR BYSTANDERS AND DAMAGE TO PROPERTY.



WARNING: IN SOME CASES, A ROUND OF AMMUNITION NOT SPECIFIED ON YOUR FIREARM AND NOT LISTED AS ALTERNATE AMMUNITION IN THIS MANUAL, MAY FIT INTO THE CHAMBER. FIRING THIS AMMUNITION MAY CAUSE A RUPTURE RESULTING IN DAMAGE TO THE FIREARM AND PERSONAL INJURY OR DEATH TO THE SHOOTER OR BYSTANDERS. FOR MORE INFORMATION REGARDING GENERALLY ACCEPTED FIREARMS AND AMMUNITION INTERCHANGEABILITY, REFER TO THE FOLLOWING URL: [HTTPS://SAAMI.ORG/WP-CONTENT/UPLOADS/2021/10/SAA-MI-GENERALLY-ACCEPTED-FIREARMS-AND-AMMUNITION-INTERCHANGEABILITY-10-8-2021.PDF](https://saami.org/wp-content/uploads/2021/10/saami-generally-accepted-firearms-and-ammunition-interchangeability-10-8-2021.pdf)



WARNING: ALWAYS INSPECT YOUR AMMUNITION BEFORE USING IT. NEVER USE DIRTY, CORRODED OR DAMAGED AMMUNITION. A BURST CARTRIDGE MAY RESULT CAUSING DAMAGE TO THE FIREARM AND PERSONAL INJURY OR DEATH TO THE SHOOTER OR BYSTANDERS.

AMMUNITION CONTINUED



WARNING: NEVER USE NON-STANDARD, RELOADED OR “HANDLOADED” AMMUNITION WHICH HAS NOT BEEN SUBJECTED TO INTERNAL BALLISTIC PRESSURE TESTING. RELOADED OR HANDLOADED AMMUNITION, MAY HAVE MANY MANUFACTURING AND QUALITY VARIABLES (SUCH AS THE TYPE AND AMOUNT OF GUN POWDER). CARTRIDGE CASES THAT HAVE BEEN RELOADED AND FIRED MULTIPLE TIMES MAY SUFFER PHYSICAL DAMAGE WHICH COULD SIGNIFICANTLY IMPACT OR REDUCE THE INTEGRITY OF THE CARTRIDGE, POSSIBLY RESULTING IN BULLET SETBACK OR UNSEATING. CASE FAILURE AND INJURY TO THE SHOOTER OR BYSTANDERS AND DAMAGE TO THE FIREARM MAY RESULT WHEN SUCH A ROUND IS FIRED. ANY AMMUNITION THAT IS IMPROPERLY MANUFACTURED OR RELOADED, EVEN IN THE SLIGHTEST DEGREE, MAY FAIL TO FIRE OR MAY GENERATE EXCESSIVE INTERNAL PRESSURES WHICH CAN DAMAGE OR EVEN RUPTURE THE FIREARM, CAUSING PERSONAL INJURY OR DEATH TO THE SHOOTER OR THOSE IN THE IMMEDIATE VICINITY.



WARNING: DISCHARGING FIREARMS IN POORLY VENTILATED AREAS, CLEANING FIREARMS, OR HANDLING AMMUNITION MAY RESULT IN EXPOSURE TO LEAD AND OTHER SUBSTANCES KNOWN TO CAUSE BIRTH DEFECTS, REPRODUCTIVE HARM, AND OTHER SERIOUS PHYSICAL INJURY. HAVE ADEQUATE VENTILATION AT ALL TIMES. WASH HANDS THOROUGHLY AFTER EXPOSURE.



WARNING: NEVER USE AMMUNITION OF THE INCORRECT GAUGE OR CALIBER. USING AMMUNITION OF THE INCORRECT GAUGE OR CALIBER MAY CAUSE DAMAGE TO YOUR FIREARM AND POSSIBLE SERIOUS INJURY TO YOU AND TO OTHERS.



WARNING: DEATH, SERIOUS INJURY AND PROPERTY DAMAGE CAN RESULT FROM THE USE OF INCORRECT AMMUNITION OR BORE OBSTRUCTIONS. NEVER USE RELOADED AMMUNITION THAT HAS NOT BEEN SUBJECTED TO INTERNAL BALLISTIC PRESSURE TESTING.

- A firearm and ammunition are a system and must work together. There are different types of ammunition for different types of firearms. Your firearm has been designed for ammunition of a specific type and a specific gauge or caliber. It is important to select the proper ammunition for your firearm.
- Different combinations of bullet velocity, bullet weight and firearm weight can have major affect on felt recoil; high felt recoil can be uncomfortable to some shooters.

AMMUNITION CONTINUED



WARNING: NEVER USE CARTRIDGES OTHER THAN THOSE DESIGNATED BY THE MARKING ON THE FIREARM UNLESS SPECIFIED IN THIS MANUAL. DOING SO MAY CAUSE SERIOUS INJURY OR DEATH TO THE SHOOTER OR BYSTANDERS AND DAMAGE TO PROPERTY.

ALTERNATE AMMUNITION: Select cartridges can be used in firearms so marked from the following list:

ALTERNATE AMMUNITION: Select cartridges can be used in firearms so-marked from the following list:			
MARKING ON FIREARM		CAN ALSO FIRE	
<i>Full Name</i>	<i>Abbreviated Name(s)</i>		
5.56x45mm NATO	5.56 5.56x45 5.56 NATO	223 Remington	223 REM
308 WINCHESTER	308 WIN	7.62x51 NATO	-

NATO ammunition has a ⊕ head stamp

CAUTION: Use of ammunition manufactured with corrosive primers in this firearm will cause oxidation to develop on any exposed metal parts of the firearm. To prevent such oxidation, the residue from corrosive primers must be completely removed from all exposed metal parts after each time ammunition with corrosive primers is used in this firearm. Conventional oil or solvent-based firearm cleaners WILL NOT dissolve the residue from corrosive primers. Residue from corrosive primers MUST be completely dissolved with a water-based cleaner. After the corrosive residue has been completely dissolved from all exposed metal parts, remove any excess water-based cleaner from the firearm. Finally, lubricate the firearm as instructed in the Safety and Instruction Manual. Failure to follow these instructions will cause damage to the firearm and may affect the ability of the firearm to function properly.

- Check with the ammunition manufacturer or a qualified gunsmith if you are unsure whether the particular ammunition you plan to use in this firearm has been manufactured with corrosive primers. If in doubt, follow all the instructions above to prevent oxidation caused by ammunition manufactured with corrosive primers.
- Ammunition manufactured by SAAMI member companies do not use corrosive primers.

MODEL AND FEATURES IDENTIFICATION

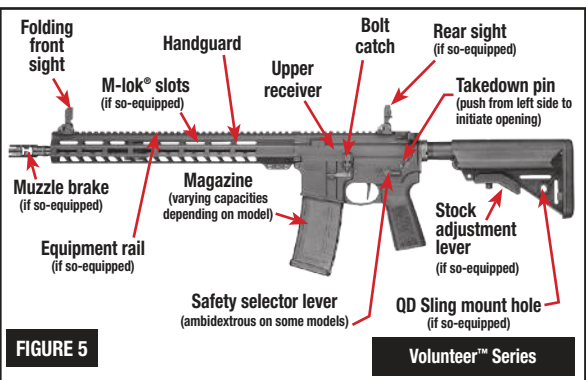
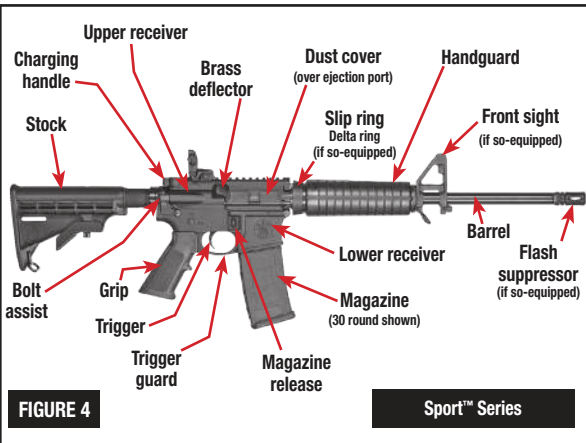
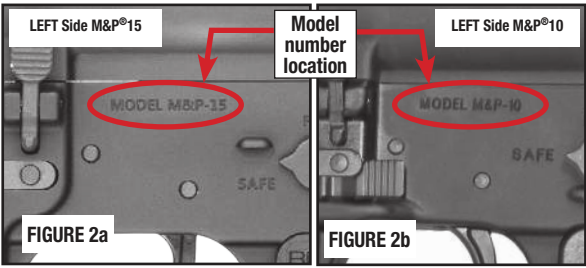

MODEL AND FEATURES IDENTIFICATION CONTINUED

- There are several types of charging handles used on various models. They operate differently but perform the same function.

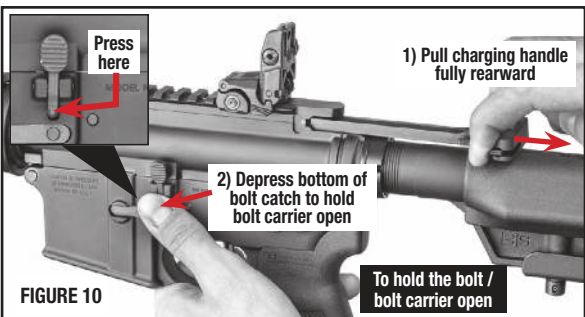
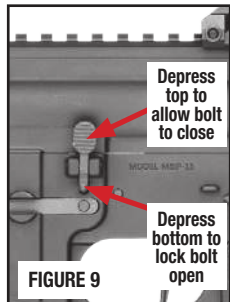
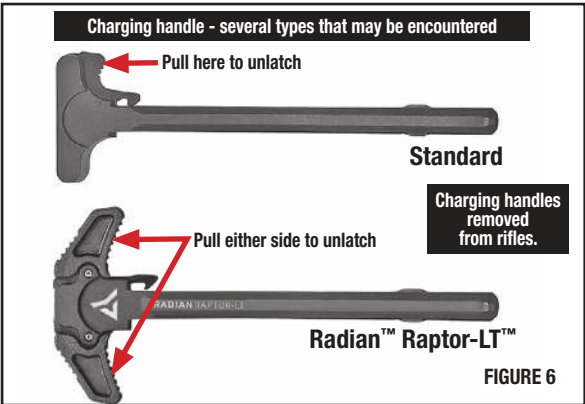

MODEL AND FEATURES IDENTIFICATION CONTINUED

- Details about parts of the bolt/bolt carrier used in this rifle design (FIGURES 11 and 12). This terminology is used throughout this manual and applies to all models.

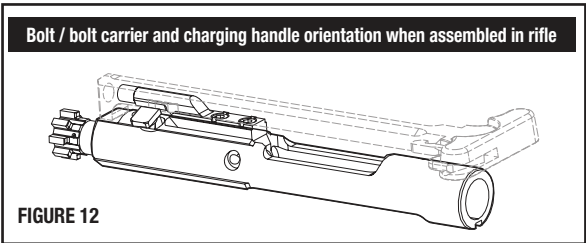
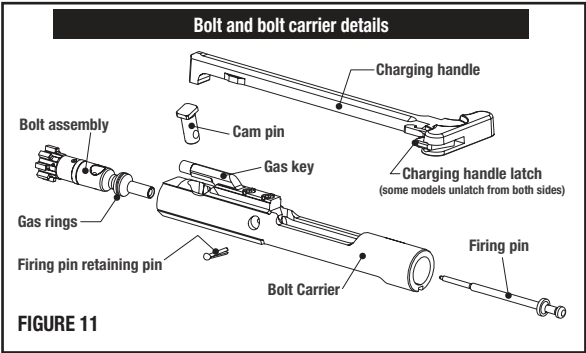

- Magazine release button (FIGURE 13). Press button in to release magazine from rifle.
- Standard charging handle latch location (FIGURE 14).
- Use 2 fingers to pull charging handle straight back (FIGURE 15). This unlatches the charging handle and cycles the bolt/bolt carrier.

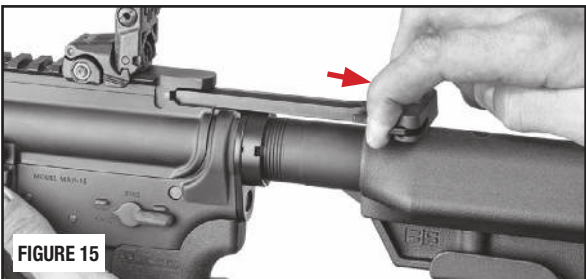
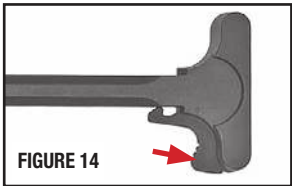
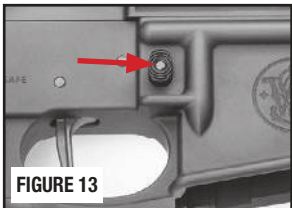

MODEL AND FEATURES IDENTIFICATION CONTINUED

- The charging handle must be manually returned to the latched (closed) position after cycling the bolt (FIGURE 16).

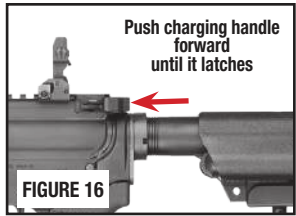

NOTE: The ambidextrous controls (FIGURES 17 and 18) on the M&P®10 Sport™ Series and Volunteer™ Series models include: the bolt catch, magazine release and safety selector lever. These controls perform the same function from either side of the firearm.

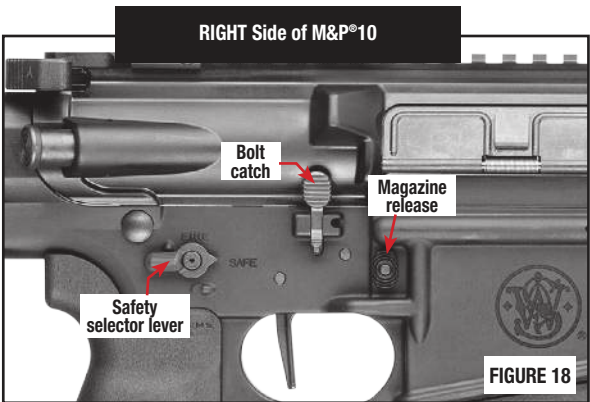
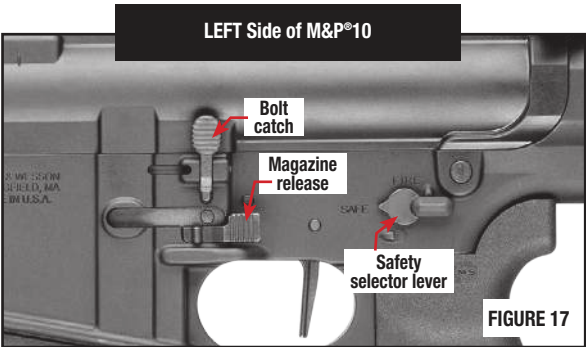

NOTE: Some M&P®15 Volunteer™ Series rifles have ambidextrous safety selector levers. These safety selector levers perform the same function from either side of the firearm.

INSPECTING YOUR FIREARM



WARNING: ALWAYS KEEP THE MUZZLE POINTED IN A SAFE DIRECTION.



WARNING: ALWAYS ENSURE THAT THE FIREARM IS UNLOADED BEFORE INSPECTING, DISASSEMBLING, ASSEMBLING OR CLEANING.



WARNING: REMOVING THE MAGAZINE FROM A SMITH & WESSON® M&P® RIFLE DOES NOT UNLOAD THE CHAMBER. THE FIREARM CAN FIRE WITH THE MAGAZINE REMOVED, IF A ROUND HAS BEEN CHAMBERED AND THE SAFETY IS PLACED INTO THE FIRE POSITION AND THE TRIGGER IS THEN PULLED TO THE REAR.

- When you inspect your rifle, you should first check to ensure that it is unloaded. To do this, grasp the rifle with your finger off the trigger and outside the trigger guard, point the muzzle in a safe direction, depress the magazine release and remove the magazine (FIGURE 19).



FIGURE 19

- Place safety selector lever on “SAFE” (FIGURE 20). If the safety lever won’t rotate to the “SAFE” position - pull the charging handle (uniformly by both sides) all the way back, press and hold the lower portion of the bolt catch down (FIGURE 21) while you release pressure on the charging handle. This will lock the bolt in the open position.

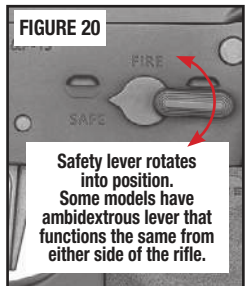

FIGURE 20

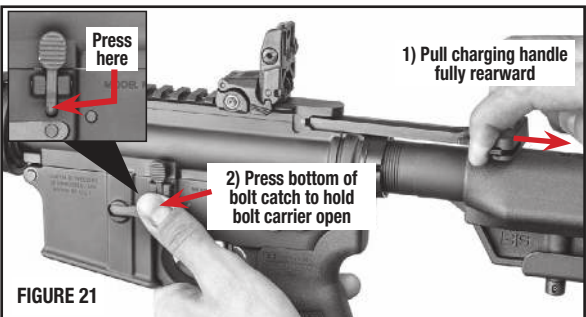

FIGURE 21

INSPECTING YOUR FIREARM CONTINUED

- Return the charging handle manually (fully forward) to the latched (locked forward) position after cycling the bolt.
- Remove the empty chamber flag from the firearm if one is present (FIGURE 22).



- Look into the ejection port and check the chamber and magazine well to be sure no cartridges are present (FIGURE 23).



- You must follow this procedure every time a firearm leaves your hand, is cleaned, handed to you or another person, transported or stored.
- Unload the magazine by holding it with the bullet end of the cartridge pointing away from you and others and pressing each cartridge forward and out of the magazine (FIGURE 24).

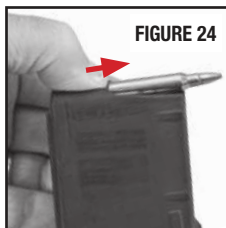

WARNING: NEVER RELY ON MECHANICAL FEATURES ALONE. ONLY YOUR SAFE FIREARM HANDLING WILL ENSURE THE SAFE USE OF YOUR FIREARM. THIS IS YOUR RESPONSIBILITY.

- Before using your firearm for the first time, it should be cleaned. See the Cleaning Section of this manual starting on page 44.

PREPARATION FOR FIRING



WARNING: THE FAILURE TO FOLLOW THESE FIREARM SAFETY REQUIREMENTS MAY RESULT IN SERIOUS PERSONAL INJURY OR DEATH TO YOU OR OTHERS.

- **ALWAYS TREAT ALL FIREARMS AS IF THEY ARE LOADED.**
- **ALWAYS BE SURE THAT ALL ACTIONS OF FIREARMS ARE OPEN, THAT CHAMBERS ARE CLEAR OF CARTRIDGES AND MAGAZINES ARE REMOVED OR UNLOADED, AND THAT FIREARM IS POINTING IN A SAFE DIRECTION.**
- **ALWAYS KEEP FINGERS AND OTHER BODY PARTS AWAY FROM THE MUZZLE AND AWAY FROM THE EJECTION PORT.**
- **ALWAYS WEAR ADEQUATE AND PROPER HEARING PROTECTION SPECIFIED FOR FIREARM USE** to prevent permanent damage to your hearing. Make sure others who are nearby are wearing hearing protection as well.
- **ALWAYS WEAR SAFETY GLASSES SPECIFIED FOR FIREARM USE,** whether indoors or out. Safety glasses should protect your eyes from the firing flash and particles associated with the discharge of ammunition. Failure to do so creates a risk of personal injury from particle or debris spitting or from a ricochet.
- **ALWAYS BE ALERT AND ALWAYS FOLLOW THE SAFETY INSTRUCTIONS OF THE RANGE OFFICER.** Never shoot if you are tired, cold or impaired in any way.
- **ALWAYS BE AWARE OF OTHER PEOPLE** so that persons do not accidentally walk into the line of fire.
- **THE SHOOTER (AND ALL OTHERS IN THE SHOOTING AREA) MUST ALWAYS BE IN A POSITION THAT IS OUT OF THE LINE OF FIRE** and are not within an area where they may be struck by a ricochet or particles spitting from a firearm, or by ejected cases from some types of firearms.
- **NEVER SHOOT AT SURFACES THAT MAY CAUSE A RICOCHET.** Always be sure of where the bullet will strike and shoot only where there is a safe back stop free of obstructions, water or other surfaces which can cause a ricochet. Be sure your bullet will stop behind your target. Bullets can glance off many surfaces like rocks or the surface of water and travel in unpredictable directions with considerable velocity.
- **NEVER FIRE RANDOMLY INTO THE SKY.** Always select a place to shoot that has a safe backstop.
- **NEVER USE ALCOHOL OR DRUGS BEFORE OR WHILE SHOOTING OR HANDLING ANY FIREARM.**

LOADING



WARNING: ALWAYS POINT THE MUZZLE OF THE FIREARM IN A SAFE DIRECTION.

- Do not load the rifle until you have read and fully understand this manual.
- Do not load the rifle until you are ready to use it. Keep your finger off the trigger and outside the trigger guard until you are ready to fire.
- Never load your rifle until you are sure of your target, what is beyond it and are fully prepared to fire.

- Press the magazine release and remove the magazine from the firearm (FIGURE 25).

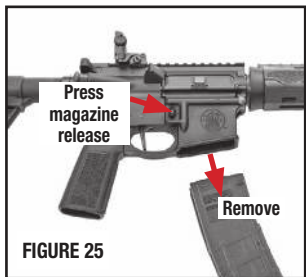

- Pull the charging handle all the way back and press the bottom of the bolt catch down and release pressure on the charging handle. This will lock the bolt in the open position (FIGURE 26).

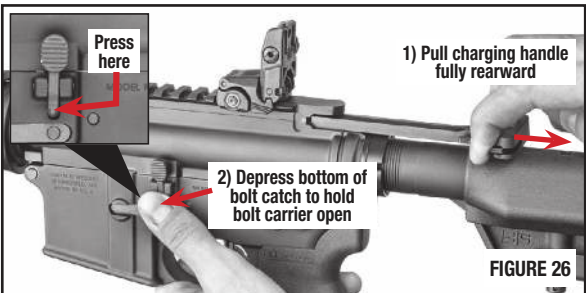

- Return charging handle fully forward until it locks and remove finger from bolt catch (FIGURE 27).



- Set safety selector lever to "SAFE" (FIGURE 28).



LOADING CONTINUED

- Orient the magazine as shown (FIGURE 29). Place a round between the lips of the magazine with the bullet forward. Press the round down and back until it is held by the magazine lips. Slide the next round in on top of the previous round and repeat until the desired number is loaded (FIGURE 30).



FIGURE 29



FIGURE 30

WARNING: DO NOT CARRY THIS RIFLE WITH THE BOLT OPEN AND A LOADED MAG-

AZINE IN THE RIFLE. ALSO, DO NOT CARRY THIS RIFLE WITH THE BOLT OPEN AND A ROUND IN THE CHAMBER. AN UNINTENTIONAL DISCHARGE MAY RESULT IF THE BOLT SLAMS CLOSED REGARDLESS OF THE POSITION OF THE SAFETY LEVER. AN UNINTENTIONAL DISCHARGE COULD RESULT IN DEATH OR INJURY TO THE SHOOTER OR BYSTANDERS AND DAMAGE TO PROPERTY.

WARNING: ALWAYS LOAD A ROUND INTO THE CHAMBER BY FEEDING IT FROM THE MAGAZINE. NEVER ATTEMPT TO LOAD THE FIREARM BY INSERTING A ROUND INTO THE OPEN EJECTION PORT. AN UNINTENTIONAL DISCHARGE COULD RESULT, POSSIBLY RESULTING IN INJURY OR DEATH TO THE SHOOTER OR BYSTANDERS AND DAMAGE TO PROPERTY.

- Smith & Wesson® has provided you with a magazine designed to operate in your specific model of firearm. While your magazine may be able to be inserted into another model firearm, it will only function properly in the specific model for which it was designed. Do not interchange magazines from one model firearm to another.
- Follow instructions in this manual and any other specific instructions which may be marked onto, or accompany, a magazine. Failure to use the particular type of magazine specified for your model and caliber of firearm may result in a malfunction.
- With the bullet end of the cartridge pointing forward, insert the loaded magazine into magazine well until it is securely locked in (FIGURE 31). Check fitment by putting some downward pressure on magazine to confirm that it is latched in place.



FIGURE 31

LOADING CONTINUED



WARNINGS: THE USER OF THESE FIREARMS MAY EXPERIENCE AN UNINTENTIONAL DISCHARGE WHEN A ROUND IS FED INTO THE CHAMBER FROM THE MAGAZINE, OR IF THE RIFLE IS DROPPED OR IT RECEIVES A BLOW TO THE MUZZLE OR FRONT OF THE FIREARM ONCE A ROUND IS CHAMBERED. AN UNINTENTIONAL DISCHARGE CAN OCCUR REGARDLESS OF THE POSITION OF THE SAFETY LEVER. AN UNINTENTIONAL DISCHARGE COULD RESULT IN DEATH OR INJURY TO THE SHOOTER OR BYSTANDERS AND DAMAGE TO PROPERTY.



WARNING: ALWAYS POINT THE MUZZLE IN A SAFE DIRECTION WHEN YOU RELEASE THE BOLT.

- Keep fingers away from ejection port and keep the muzzle pointed in a safe direction. Press in on the top of the bolt catch (FIGURE 32) to release the bolt carrier/bolt, which will move forward and feed a round from the magazine into the chamber.

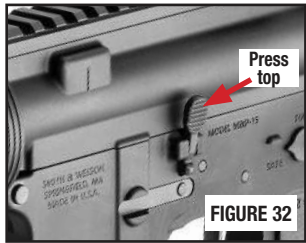

WARNING: UPON RELEASING THE BOLT CARRIER/BOLT FROM THE OPEN POSITION, THE MECHANISM MOVES FORWARD WITH SIGNIFICANT FORCE AND SPEED. TO AVOID INJURY, BE SURE NO PART OF YOUR BODY IS IN THE PATH OF THE BOLT CARRIER/BOLT DURING ITS TRAVEL.

- The firearm is now loaded and will fire if the safety selector lever is rotated into the “FIRE” position and the trigger is pulled.
- If the bolt does not completely close, press the bolt assist (FIGURE 33). This should move the bolt completely forward. If the bolt assist does not fully chamber the round, see the Misfeeds/Jams section of this manual on page 26.



LOADING CONTINUED



WARNING: IF THE CARTRIDGE FAILS TO STRIP FROM THE MAGAZINE OR FULLY SEAT INTO THE CHAMBER, IMMEDIATELY STOP THE LOADING PROCESS. REMOVE THE MAGAZINE, LOCK THE ACTION OPEN AND VERIFY THAT THE CHAMBER IS EMPTY. REFER TO THE “INSPECTING YOUR FIREARM” SECTION OF THIS MANUAL.



WARNING: NEVER STRIKE OR DROP THE FIREARM. DOING SO MAY CAUSE A ROUND TO CHAMBER IF A LOADED MAGAZINE IS IN THE RIFLE. AN UNINTENTIONAL DISCHARGE MAY RESULT IF THE BOLT CLOSES AND A ROUND IS CHAMBERED REGARDLESS OF THE POSITION OF THE SAFETY LEVER, POSSIBLY LEADING TO DEATH OR INJURY TO THE SHOOTER OR BYSTANDERS AND DAMAGE TO PROPERTY.



WARNING: SMITH & WESSON® M&P RIFLES WILL FIRE WITH THE MAGAZINE REMOVED. KEEP YOUR FINGER OFF THE TRIGGER AND OUTSIDE THE TRIGGER GUARD UNTIL YOU HAVE MADE THE COMMITMENT TO FIRE.

- You may now manually close the ejection port dust cover (if your rifle is so-equipped) by raising it and “clicking” it into the closed position - covering the ejection port and bolt (FIGURE 34).
- The dust cover opens automatically when the bolt carrier moves during firing or loading/unloading. It can stay open during normal use and does not influence operation of the rifle.



FIRING



WARNING: ALWAYS KEEP THE MUZZLE POINTED IN A SAFE DIRECTION.



WARNING: WEAR EYE AND HEARING PROTECTION SPECIFIED FOR FIREARM USE EVERY TIME YOU DISCHARGE YOUR FIREARM. MAKE SURE OTHERS IN THE VICINITY OF WHERE YOU WILL BE SHOOTING DO SO AS WELL.

- Grasp firearm with one hand on handguard and other hand on firearm grip with index finger resting along outside of trigger guard. Raise firearm and pull buttstock firmly into shoulder (FIGURE 35).

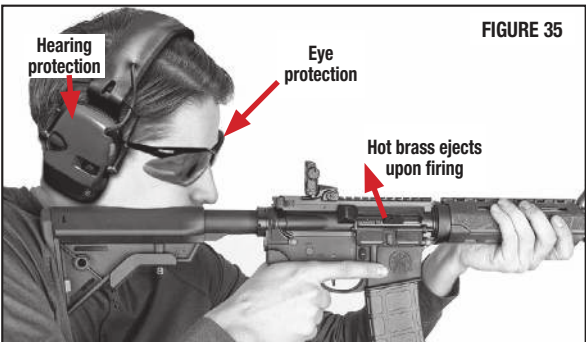

- Rotate the safety selector until it points to the “FIRE” position (FIGURE 36).
- Keeping steady aim, place index finger on trigger and pull gently until the rifle fires. Your firearm chambers the next round immediately after firing.
- You may continue to fire by pulling and fully releasing the trigger until the magazine is empty.
- If you wish to stop firing, release trigger, remove finger from trigger guard and rotate safety lever to point at “SAFE” (FIGURE 37). If you have fired the last round from the magazine, the bolt will be held to the rear so that the firearm can be reloaded by replacing the magazine, or the chamber can be inspected to ensure that it is empty (FIGURE 38).

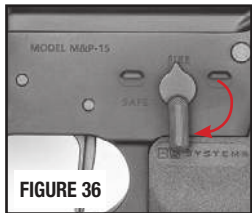

HANGFIRES AND MISFIRES



WARNING: ALWAYS KEEP THE MUZZLE POINTED IN A SAFE DIRECTION.



WARNING: WEAR EYE AND HEARING PROTECTION SPECIFIED FOR USE WITH FIREARMS WHEN FIRING AND CLEARING MISFIRES OR MISFEEDS.



WARNING: KEEP YOUR FACE A SAFE DISTANCE FROM THE EJECTION PORT WHEN CLEARING A CARTRIDGE. IF A CARTRIDGE IGNITES WHILE BEING CLEARED FROM THE FIREARM, DEATH OR SERIOUS INJURY MAY RESULT.



WARNING: IF YOUR FIREARM GIVES ANY INDICATION THAT IT IS NOT PERFORMING PROPERLY OR THE OPERATION OF YOUR FIREARM HAS CHANGED “THE WAY IT FEELS OR SOUNDS”, STOP FIRING. MAKE SURE THE FIREARM IS POINTED IN A SAFE DIRECTION, UNLOAD THE FIREARM AND HAVE IT INSPECTED AND TEST FIRED BY A GUNSMITH QUALIFIED TO PERFORM SERVICES ON SMITH & WESSON® FIREARMS.

NOTE: In the case of either a hangfire or misfire, keep the muzzle pointed in a safe direction and your finger off the trigger. Wait 60 seconds, then press the magazine release button and remove the magazine from the firearm (FIGURE 39). Proceed to clear the unfired cartridge from the chamber.



- A **HANGFIRE** is described as a noticeable delay between the impact of the firing pin on the primer of the cartridge and the actual discharge of the firearm. This is generally caused by defective or damaged ammunition.
- If a cartridge has delayed ignition and goes off after a delay, with the firearm pointed in a safe direction, the magazine should be removed and the firearm should be unloaded. The remainder of similar ammunition should be inspected to determine if it has been contaminated or damaged and dealt with accordingly.
- A **MISFIRE** is the failure of the chambered cartridge to fire at all after the trigger has been pulled. This is generally caused by defective or damaged ammunition or a dirty or fouled firearm.

HANGFIRES AND MISFIRES CONTINUED

- A light primer strike caused by a dirty or fouled firearm can lead to misfires. If a light indent on the primer of a misfire is noted, unload the firearm and clean it as instructed in the Cleaning and Maintenance section of this manual. If the cartridge does not go off, the “dud” cartridge needs to be removed from the firearm.
- Pull the charging handle all the way back and then press the lower portion of the bolt catch in. Let the bolt move forward against the bolt catch (FIGURE 40). This will lock the bolt in the open position. Remove your finger from bolt catch.

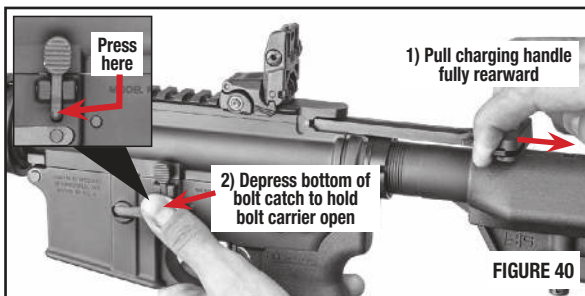

- Return the charging handle fully forward until it locks (FIGURE 41).
- Rotate the safety lever to the SAFE position (FIGURE 42).
- Visually check the chamber to be sure no cartridges are present (FIGURE 43).
- The firearm should be inspected and cleaned before returning it to use.
- The ammunition should be inspected and damaged or defective rounds should not be used.
- Damaged or defective ammunition should be disposed of properly.



CLEARING A MISFEED/JAM

NOTE: Any autoloading firearm may, on occasion, fail to feed a cartridge properly from the magazine and into the chamber. If this should occur:



WARNING: KEEP YOUR FACE A SAFE DISTANCE FROM THE EJECTION PORT WHEN CLEARING A MISFED/JAMMED CARTRIDGE. A CARTRIDGE MAY IGNITE IF THE PRIMER OF THE CARTRIDGE IS STRUCK WITH SUFFICIENT FORCE. IF A CARTRIDGE IGNITES WHILE BEING CLEARED FROM THE FIREARM, DEATH OR SERIOUS INJURY MAY RESULT.

TO CLEAR A MISFEED (“JAM”)

- Make certain that the muzzle is pointed in a safe direction.
- Press and hold the magazine release and remove the magazine from the rifle (FIGURE 44).
- Pull the charging handle back and engage the bolt catch to lock the bolt open (FIGURE 45).

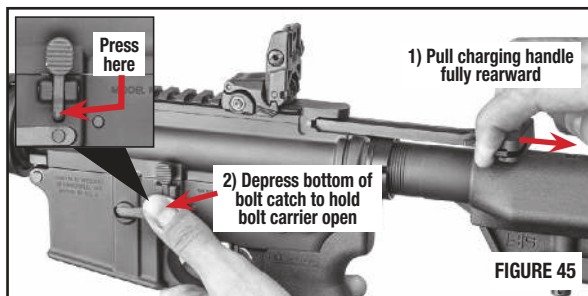

- Rotate the safety lever into the “SAFE” position (FIGURE 46).

NOTE: Drawing the bolt fully to the rear should allow clearance for the jammed cartridge to fall free and clear of the firearm.

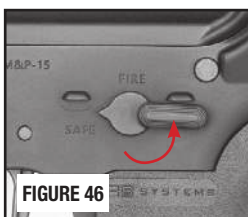

- It may be necessary to manually remove a jammed cartridge. When attempting to clear a jam manually, use only wood ‘tools’, such as a pointed dowel or a pencil, and use extreme care to avoid striking the primer of the cartridge.

CLEARING A MISFEED/JAM CONTINUED

- Visually check to make sure all cartridges have been removed from the firearm (FIGURE 47).

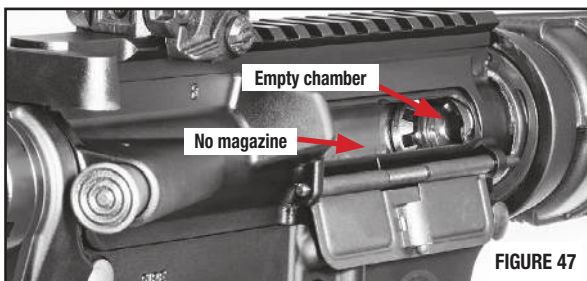

- Once the misfed cartridge is cleared, proceed to load the firearm as instructed in the Loading Section of this manual.
- Dispose of defective cartridge(s) in a method specifically approved for live round disposal.

UNLOADING



WARNING: ALWAYS KEEP THE MUZZLE POINTED IN A SAFE DIRECTION.



WARNING: REMOVING THE MAGAZINE FROM A SMITH & WESSON® M&P® RIFLE DOES NOT UNLOAD THE CHAMBER. THE FIREARM CAN FIRE WITH THE MAGAZINE REMOVED, IF A ROUND HAS BEEN CHAMBERED AND THE SAFETY IS PLACED INTO THE FIRE POSITION AND THE TRIGGER IS THEN PULLED TO THE REAR.

- Press magazine release and remove magazine from the rifle (FIGURE 48).
- Pull charging handle fully to the rear and push in lower portion of bolt catch to hold bolt open (FIGURES 49).

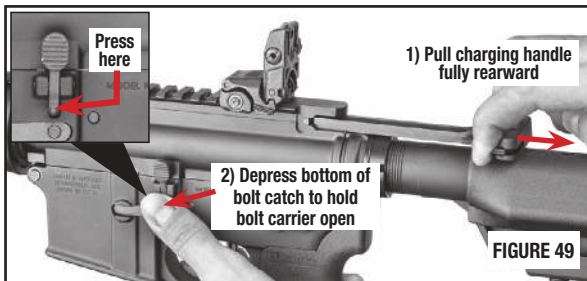

UNLOADING CONTINUED

- Return the charging handle to the forward (closed) position (FIGURE 50).
- Set safety selector lever to “SAFE” (FIGURE 51).
- Look into the chamber through ejection port to ensure that the chamber is empty (FIGURE 52).
- Remove remaining live rounds from the magazine by sliding them forward and out of the magazine (FIGURE 53).
- Collect live ammunition for safe storage and spent cartridge cases for proper disposal.

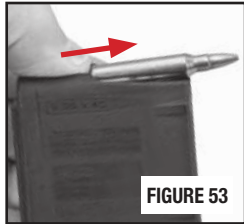
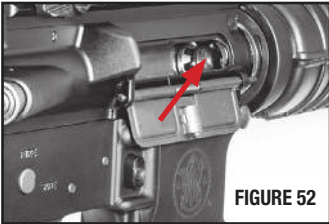
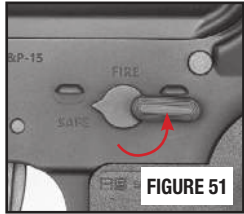

DISASSEMBLY/FIELD STRIPPING



WARNING: ALWAYS KEEP THE MUZZLE POINTED IN A SAFE DIRECTION.



WARNING: NEVER DO ANYTHING BEYOND WHAT YOU ARE SPECIFICALLY INSTRUCTED TO DO IN THIS MANUAL. NEVER ALTER OR MODIFY THE PARTS IN YOUR FIREARM.



WARNING: WEAR SAFETY GLASSES THAT ARE SPECIFIED FOR FIREARMS USE EVERY TIME YOU DISASSEMBLE OR ASSEMBLE YOUR FIREARM.



WARNING: ANY MAINTENANCE, ADJUSTMENT OR SERVICE NOT SPECIFIED IN THIS MANUAL MAY AFFECT THE SAFETY AND RELIABILITY OF YOUR FIREARM AND MUST BE PERFORMED BY A QUALIFIED GUNSMITH USING GENUINE SMITH & WESSON® PARTS. IF YOU DO OTHERWISE, IMPROPER FUNCTIONING OF YOUR FIREARM MAY OCCUR AND SERIOUS INJURY OR DEATH TO THE SHOOTER OR BYSTANDERS MAY RESULT.

DISASSEMBLY - FIELD STRIPPING CONTINUED

- Press magazine release and remove magazine from the rifle (FIGURE 54).
- Place the safety in the "SAFE" position (FIGURE 55).

NOTE: When handling a Smith & Wesson® M&P® rifle; if the safety selector does not easily rotate to the "SAFE" position, DO NOT attempt to force it into "SAFE". While keeping the muzzle pointed in a safe direction, remove the magazine and lock your bolt open and then rotate the safety selector to "SAFE" before proceeding.

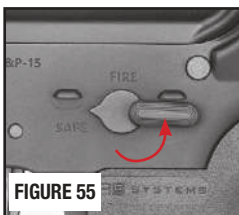

- Push the top of the bolt release to allow the bolt to move fully forward to the closed position (FIGURE 56).
- Push in takedown pin above and behind the trigger (FIGURE 57) from left side.

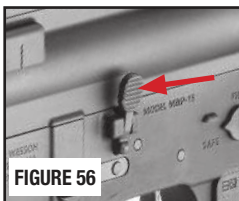

- Pull the pin out on the right side of the receiver until it comes to a positive stop (FIGURE 58). The takedown pin is captive and does not come fully out.



- Pivot lower receiver down and away from upper receiver (FIGURE 59).

NOTE: Never dry-fire the rifle when it is disassembled. Damage to the parts may result.

- If required, remove pivot pin from the front of receiver (in a similar manner to the rear pin) and separate the upper receiver from the lower receiver completely.

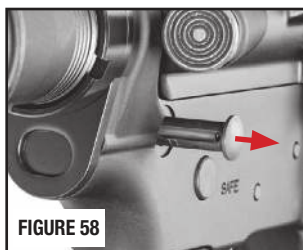

DISASSEMBLY - FIELD STRIPPING CONTINUED

- Unlatch and pull the charging handle to rear as shown here (FIGURE 60).
- Once the charging handle is pulled rearward, remove bolt carrier assembly down and back out of the upper receiver (FIGURE 61).

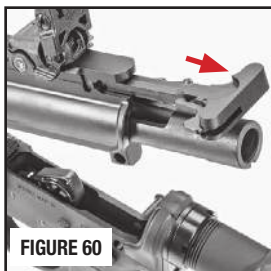

- Remove charging handle by pulling it backwards to the takedown notch (FIGURE 62) and then down out of the upper receiver - this image shows the charging handle takedown notch (as seen from the bottom of the upper receiver).
- (FIGURE 63) shows the bolt carrier/ bolt assembly and charging handle removed from the upper receiver.

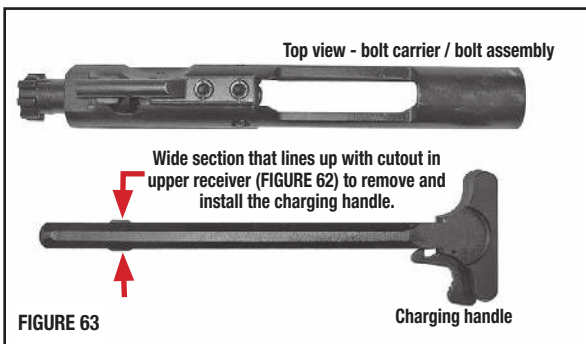
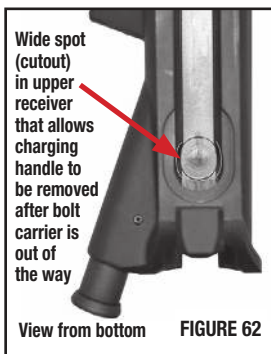

SPECIAL COMPONENT DISASSEMBLY



WARNING: ALWAYS ENSURE THAT THE RIFLE IS UNLOADED BEFORE ANY PROCEDURE IS ATTEMPTED.



WARNING: WEAR SAFETY GLASSES EVERY TIME YOU DISASSEMBLE OR ASSEMBLE YOUR FIREARM.

NOTE: When handling the Smith & Wesson® M&P® rifle; if the safety selector does not easily rotate to the “SAFE” position, DO NOT attempt to force it into “SAFE”. While keeping the muzzle pointed in a safe direction, remove the magazine and lock your bolt open (FIGURES 64 and 65). Rotate the safety selector to “SAFE” (FIGURE 66).



FIGURE 64

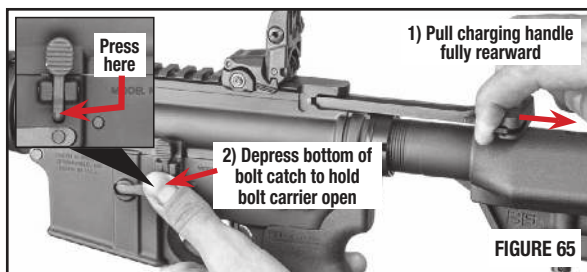

FIGURE 65

- While it is not generally necessary to remove the forend from your rifle for routine cleaning, the following information shows how to do it.

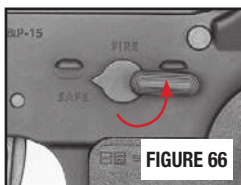

FIGURE 66

2-PIECE/SPLIT FOREND REMOVAL

- If so-equipped. Using a two-person “Buddy System”.

- Stand the rifle on its buttstock with one hand gripping the stocks and the other gripping the lower end of the handguard.
- While your “buddy” pulls down on the slip ring (Delta ring), which is generally a two-hand job, pull the handguard halves free (FIGURE 67).
- Repeat this procedure to remove the other handguard.

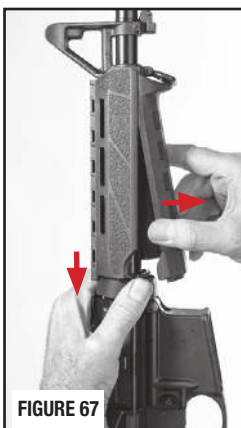
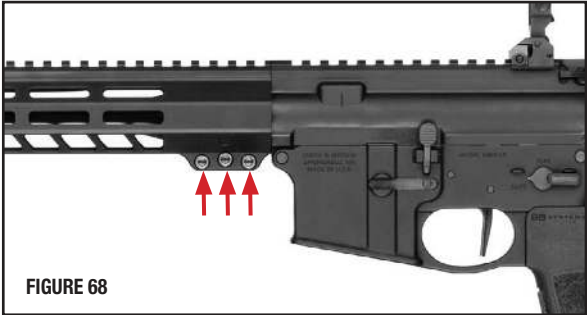

FIGURE 67

SPECIAL COMPONENT DISASSEMBLY CONTINUED

ONE-PIECE FREE-FLOATING FOREND/RAIL REMOVAL - if the rifle is so-equipped.

- To remove the free-floating aluminum forend found on many of these rifles, start by removing the (3) screws using a 5/32" Allen wrench (FIGURE 68).



NOTE: After installing and aligning Smith & Wesson® one-piece aluminum forend, tighten these (3) forend screws (FIGURE 68) securely. The forend/rail screws use a 5/32" driver and should be torqued to 45-50 inch-pounds.

BOLT CARRIER/BOLT REMOVAL/DISASSEMBLY FOR CLEANING

- With the bolt closed, push the takedown pin out to the right and tip the upper receiver open as instructed previously in this manual (FIGURE 69).
- Unlatch to charging handle and pull the bolt carrier assembly part way out of the upper receiver (FIGURE 70).
- Remove the bolt carrier assembly from the upper receiver with a down and back motion (FIGURE 70).
- After the bolt carrier is removed and set aside, pull the charging handle back and down to remove it from the upper receiver.

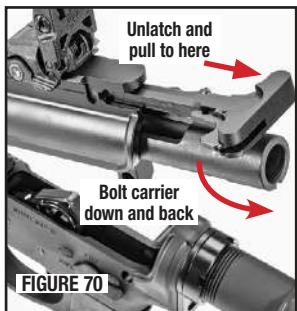
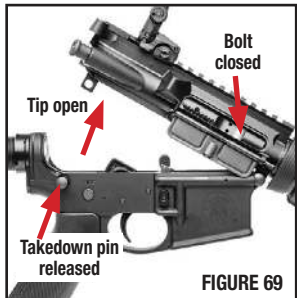

SPECIAL COMPONENT DISASSEMBLY CONTINUED

- Once the bolt carrier is removed from the firearm, grasp the bolt and pull it fully forward in the bolt carrier to the forward-most (unlocked) position (FIGURE 71).

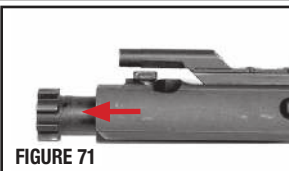

FIGURE 71

- Remove the firing pin retaining pin (FIGURE 72) with a drift or small punch. Very little effort is required to accomplish this.

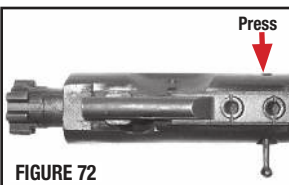

FIGURE 72

NOTE: Do not alter the split end of the firing pin retaining pin (FIGURE 73).

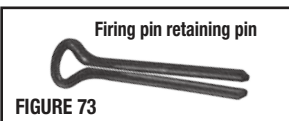

FIGURE 73

- Push the bolt back into the bolt carrier to put it in the locked position (FIGURE 74).

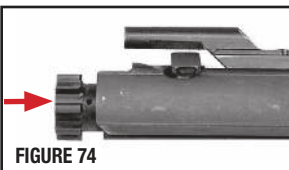

FIGURE 74

- Grasp the rear of the firing pin and remove it out of the rear of the bolt carrier (FIGURE 75).

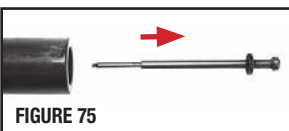

FIGURE 75

- Turn the bolt cam pin $\frac{1}{4}$ turn (FIGURE 76).

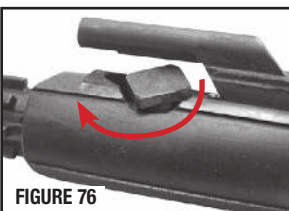

FIGURE 76

- Lift the cam pin from the bolt carrier (FIGURE 77).

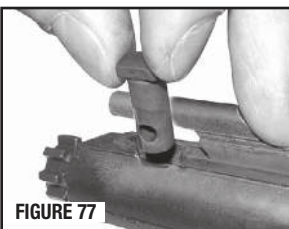

FIGURE 77

- Pull the bolt forward and out of the bolt carrier (FIGURE 78).

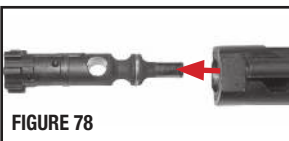

FIGURE 78

SPECIAL COMPONENT DISASSEMBLY CONTINUED

EXTRACTOR CHECK, REMOVAL AND DISASSEMBLY FOR CLEANING

- Press the rear of the extractor to check that the spring works (FIGURE 79). If there is no tension, you need to take the extractor off the bolt and clean the extractor and bolt.
- Press the extractor slightly and hold it down. Use a small drift to push the extractor pin out (FIGURE 80).
- Remove the extractor from the bolt (FIGURE 81).

NOTE: Further disassembly of the extractor parts is not needed. If the extractor spring (with internal buffer) and o-ring are dislodged during cleaning, use a flat drift to press the assembly back into the extractor.

- FIGURE 82 shows the properly arranged extractor - ready for reassembly onto the bolt.
- Clean all parts (see section on Cleaning in this manual) and reassemble in reverse order.

- Realign the extractor onto the bolt and apply some pressure to align the hole (FIGURE 83), then reinsert the extractor pin.

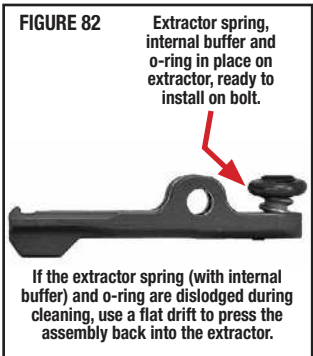
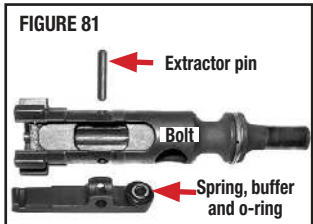
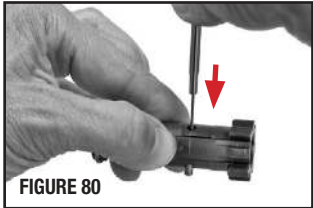
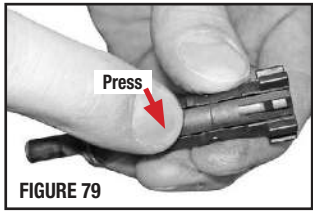

SPECIAL COMPONENT DISASSEMBLY CONTINUED

BUFFER AND BUFFER SPRING REMOVAL FOR CLEANING

- Push the buffer in slightly (at the rear of the receiver/front of the stock) and depress buffer retainer to release the buffer (FIGURE 84).
- Remove buffer and spring from the buffer tube (FIGURES 85 and 86).
- Clean all parts and reassemble in reverse order.
- If required, press the front pivot pin from the receiver (FIGURES 87a and 87b) in a similar manner to the rear pin and separate the upper receiver from the lower receiver completely. The pivot pin is captive and cannot be removed completely.

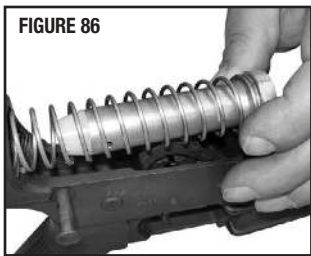
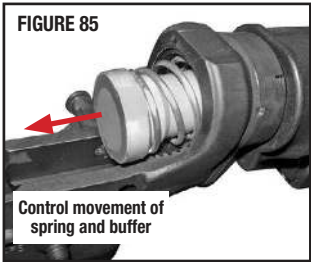
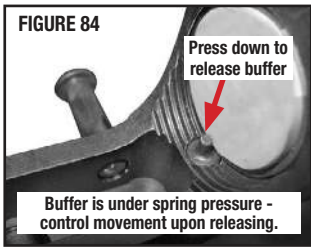

WARNING: DO NOT ALTER, MODIFY OR REPLACE ANY OF THE PARTS OF YOUR FIREARM UNLESS THIS WORK IS PERFORMED BY A QUALIFIED GUNSMITH USING GENUINE SMITH & WESSON® PARTS. IF YOU DO OTHERWISE, IMPROPER FUNCTIONING MAY OCCUR AND SERIOUS INJURY MAY RESULT.

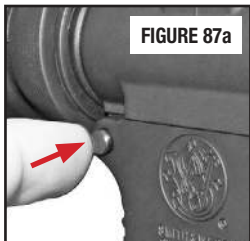

WARNING: NEVER DISASSEMBLE YOUR FIREARM BEYOND THE FIELD STRIPPING PROCESS OUTLINED IN THIS MANUAL. NEVER MANIPULATE ANY INTERNAL COMPONENTS BEYOND WHAT YOU ARE SPECIFICALLY INSTRUCTED TO DO IN THIS MANUAL SINCE THIS MAY AFFECT THE RELIABILITY, FUNCTIONING AND SAFETY OF YOUR FIREARM.

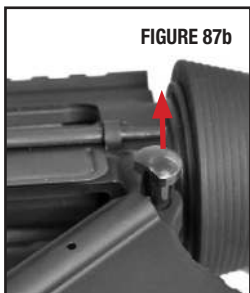

ASSEMBLY



WARNING: WEAR SAFETY GLASSES EVERY TIME YOU ASSEMBLE OR DISASSEMBLE YOUR FIREARM.



WARNING: ALWAYS FOLLOW THE FIELD STRIPPING INSTRUCTIONS EXACTLY. NEVER DO ANYTHING BEYOND WHAT YOU ARE SPECIFICALLY INSTRUCTED TO DO IN THIS MANUAL. NEVER ALTER OR MODIFY THE PARTS IN YOUR FIREARM.



WARNING: DO NOT INTERCHANGE BOLT ASSEMBLIES FROM ONE RIFLE TO ANOTHER. DOING SO MAY RESULT IN INJURY AND/OR DEATH TO THE SHOOTER OR BYSTANDERS AND DAMAGE TO PROPERTY.



WARNING: THE BOLT CAM PIN MUST BE INSTALLED PRIOR TO FIRING. IF THE BOLT CAM PIN IS NOT INSTALLED PRIOR TO FIRING, INJURY AND/OR DEATH TO THE SHOOTER OR BYSTANDERS AND DAMAGE TO PROPERTY MAY RESULT UPON FIRING.

- Assemble your rifle in the reverse order that you took it apart.

- There are 3 gas rings on the bolt. Stagger the gaps between the ends of the gas rings on the bolt when reassembling (FIGURES 88a and 88b).

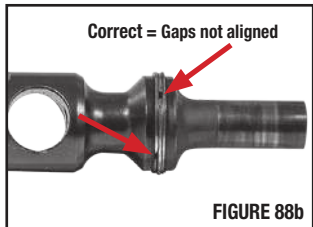
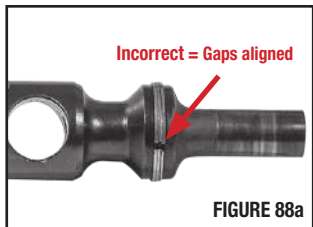

NOTE: The cam pin only goes into the bolt from one side. The “staked” side goes down when installing the bolt into bolt carrier (FIGURE 89).

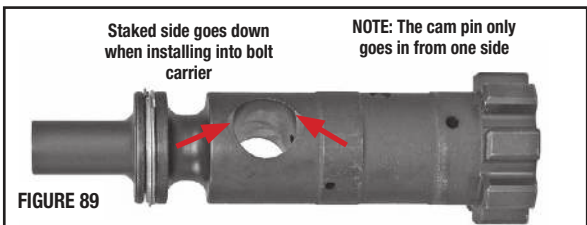

ASSEMBLY CONTINUED

- (FIGURE 90) shows the correctly assembled bolt carrier ready to go back into the upper receiver.

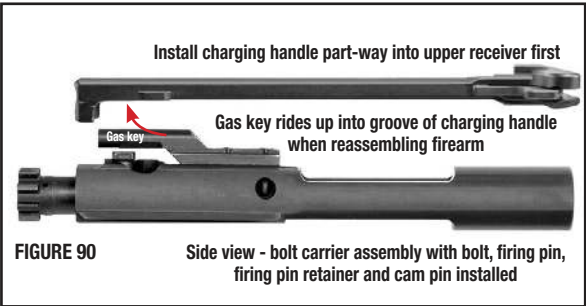

- Lubricate all metal parts by wiping them with a cloth dampened with a high-quality firearm oil. Remove excess oil. Leave a light film of oil on all metal parts of your rifle - inside and out.

COLLAPSIBLE/ADJUSTABLE STOCK (IF RIFLE IS SO-EQUIPPED)

- To extend the collapsible stock, depress lever (FIGURE 91) and pull the stock out until it locks into position.

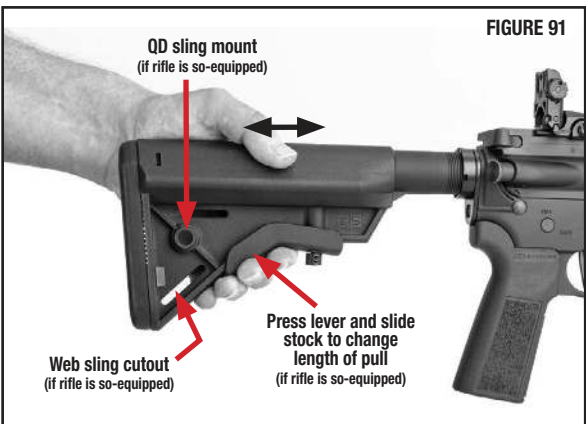

- To collapse the buttstock, depress the lever again and push forward until it locks into position.

SIGHT ADJUSTMENT (IF RIFLE IS SO-EQUIPPED)



WARNING: ALWAYS ENSURE THAT THE RIFLE IS UNLOADED BEFORE ANY PROCEDURE IS ATTEMPTED.

WILLIAMS™ DUAL APERTURE REAR SIGHT

- This sight has a dual aperture (FIGURES 92 and 93). Use the larger aperture for close-quarters sighting and in low-light conditions. Use the small aperture for longer range firing and in bright-light precision shooting conditions.
- Turning the windage adjustment clockwise moves your group to the right (“R” Right arrow is stamped into the sight knob). Turning the windage screw counter-clockwise moves the point of impact to the left (FIGURE 94).

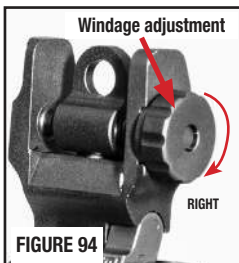
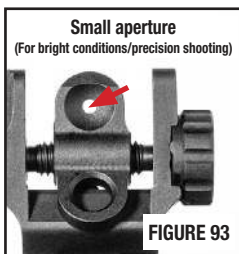
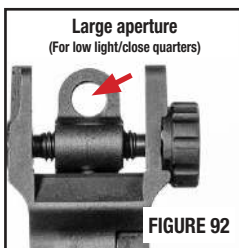

- Both the front and rear Williams™ sights can be folded down when not in use. See location of latch in (FIGURES 95 and 96).



- The Williams™ front sight (FIGURE 96) can be adjusted for elevation by depressing the detent and turning the sight post in the same manner as the A2 front sight shown in FIGURE 97.



SIGHT ADJUSTMENT CONTINUED

ADJUSTABLE A2 FRONT SIGHT POST (If rifle is so-equipped)

- If elevation adjustment is needed, the front sight post can be moved up or down (FIGURE 97).
- Depress the front sight detent and rotate the post counterclockwise to raise the post (this lowers the shot's impact on target) - and clockwise to lower the post and raise the shot's point of impact on target.

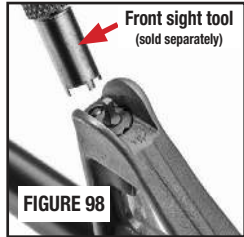
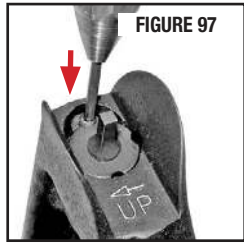

MAGPUL® MBUS® FOLDING REAR SIGHT - (If so-equipped)

- The Magpul® MBUS® spring-loaded, folding rear sight (FIGURE 99) is a dual aperture rear sight that is adjustable for windage (FIGURE 100).
- Turn the knob right to change the bullet impact to the right.
- Turn the knob left to change the bullet impact to the left.
- The sight flips up by pressing the tab from either side or by pressing the central area on top (FIGURE 99). The sight can be folded with either large or small aperture in position.

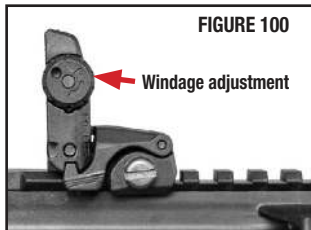
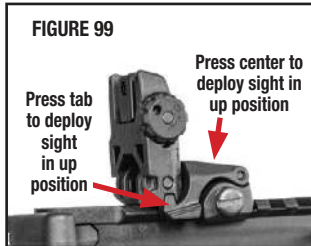

SIGHT ADJUSTMENT CONTINUED

MAGPUL® MBUS® DUAL APERTURE REAR SIGHT

- The MAGPUL® MBUS® rear sight has a dual aperture that is deployed by flipping the smaller opening aperture up into position - or forward (down) to use the large opening (FIGURES 101 thru 103). Use the larger aperture for normal range firing and in low-light conditions. Use the small aperture for longer range precision firing and in bright-light conditions.

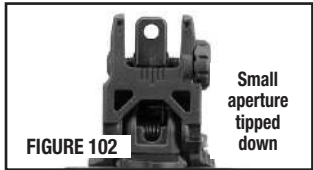

MAGPUL® MBUS® FOLDING FRONT SIGHT - (If so-equipped)

- The Magpul® MBUS® spring-loaded, folding front sight (FIGURE 104) is adjustable for elevation. It flips up by pressing the tab from either side or by pressing the central area on top. An elevation adjustment tool is included. Use the tool to turn the sight post (clockwise as viewed from top) down to raise the impact of the bullets on target and counter-clockwise (up) to lower the bullets' impact on target.

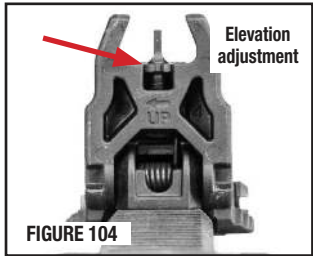

INSTALLATION OF OPTICAL SIGHTS



WARNING: ALWAYS ENSURE THAT THE FIREARM IS UNLOADED BEFORE INSTALLING A SCOPE, OPTICAL SIGHT OR ANY OTHER ACCESSORIES. FAILURE TO DO THIS CAN RESULT IN INJURY OR DEATH TO YOU OR OTHERS AND DAMAGE TO PROPERTY.



WARNING: FIRING A FIREARM WITH YOUR EYE TOO CLOSE TO THE EYE PIECE OF A SCOPE OR OPTICAL SIGHT, OR FAILING TO HOLD THE FIREARM SECURELY AGAINST RECOIL, MAY RESULT IN SERIOUS PERSONAL INJURY INCLUDING, BUT NOT LIMITED TO, BLINDNESS.



WARNING: A SCOPE OR OPTICAL SIGHT WHICH IS NOT SECURELY MOUNTED MAY BECOME DETACHED UPON RECOIL OF THE FIREARM. IF IT BECOMES DETACHED IT MAY FLY BACK AND STRIKE THE SHOOTER OR A BYSTANDER AND CAUSE INJURY. OBSERVE THE CONDITION OF ALL THE SCOPE MOUNT SCREWS AFTER FIRING. IF THE MOUNTING SCREWS SHOW SIGNS OF LOOSENING DO NOT FIRE THE GUN AGAIN; CALL THE CUSTOMER SERVICE DEPARTMENT FOR ASSISTANCE AT 1-800-331-0852 EXT 4125.

- We recommend that you have a competent gunsmith install your scope and mount.
- Scopes and optical sights have varying lengths of recommended eye relief. You need to choose a combination that allows for adequate clearance between the scope and your eye. Follow the instructions supplied with the scope and rings for proper installation (FIGURE 105).

FIGURE 105



MAGAZINE



WARNING: WEAR SAFETY GLASSES EVERY TIME YOU ASSEMBLE OR DISASSEMBLE YOUR MAGAZINE.



WARNING: MAGAZINE SPRING IS UNDER PRESSURE. CONTROL THE SPRING AND THE FLOOR PLATE RETAINER SO THAT THEY DO NOT FLY OUT AND CAUSE INJURY.

- There are various capacities and styles of magazines shipped with Smith & Wesson® rifles. Operation of these magazines is basically the same, regardless of capacity or appearance.

- FIGURE 106 shows the typical 30-round PMAG® magazine commonly shipped with and used in these rifles. Some rifles may have metal magazines that differ slightly. See the instructions for the metal magazines on the following page.

FIGURE 106



MAGPUL® PMAG® 30-ROUND MAGAZINE DISASSEMBLY

- Using a small, blunt object (such as a drift or punch), push the floorplate retainer down by passing the tool through the hole in the floorplate (FIGURE 107).
- While holding the retainer down - slide floorplate forward off of the tube while keeping your finger over the tube to prevent the spring from flying out (FIGURE 108).
- Remove floorplate, the spring and the follower out through bottom of the magazine tube.

Slide floor plate

Press down on retainer

FIGURE 107

Control spring

FIGURE 108

MAGAZINE CONTINUED

- (FIGURE 109) shows the parts that make up the typical 30-round MAGPUL® PMAG® magazine commonly used with these rifles.



MAGPUL PMAG® 30-ROUND MAGAZINE ASSEMBLY

- Install the follower, spring and floor plate retainer into the magazine tube from the bottom.
- While holding the spring down (under tension) in the tube, slide the floorplate onto the magazine tube (over the tabs) until the floorplate locks it into place.

METAL MAGAZINE

DISASSEMBLY (FIGURE 110) (If rifle is so-equipped)

- Insert 1/8" drift into hole in floor plate of magazine.
- Gently pull back on drift until locking tabs of butt plate will clear magazine tube.
- Slide butt plate off magazine tube (FIGURE 111).
- Remove magazine spring and follower.

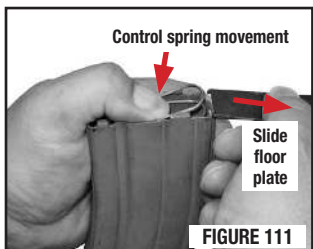
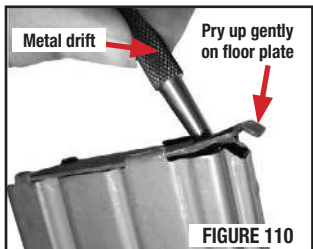

CLEANING AND MAINTENANCE



WARNING: ENSURE THAT YOUR FIREARM IS UNLOADED BEFORE BEGINNING TO CLEAN IT. (SEE “INSPECTING YOUR FIREARM” SECTION). ALWAYS FOLLOW THE RULES OF SAFE FIREARM HANDLING.



WARNING: WEAR SAFETY GLASSES EVERY TIME YOU ASSEMBLE OR DISASSEMBLE YOUR FIREARM AND ATTEMPT CLEANING OR MAINTENANCE.

- Before using your firearm for the first time, it should be cleaned.
- Your firearm was treated at the factory with either a preservative or oil to protect it against corrosion during shipping and storage.
- Preservative and oil should be wiped from the bore, chamber and exposed areas using a clean swab or patch before using the firearm.

CAUTION: Never disassemble your firearm beyond the instructions in the Field Stripping and Inspection sections of this manual.

- Purchase cleaning supplies from your firearms dealer that are specifically designated for your type and caliber of firearm. Many suppliers offer these in kit form for your convenience.
- Follow the instructions provided with your cleaning supplies.

NOTE: A basic firearm cleaning kit should include: a brass bore brush and a cleaning jag of appropriate size for the bore being cleaned, high-quality gun cleaning solvent and gun oil/lubricant, cotton cleaning patches and a cleaning rod that is long enough to push the brush and jag completely through the barrel.

- Remove excessive firing residue from the bore and chamber using a properly fitted brass brush dipped in gun cleaning solvent. Finish the bore cleaning process by running a dry cotton cloth patch through the bore and chamber to remove residue and solvent.
- Clean the exterior of the firearm using a non-abrasive cleaning cloth.
- After cleaning, lightly coat the metal parts, internal and external with a high quality firearm oil.
- Whenever your firearm has been exposed to sand, dust, extreme humidity, water or other adverse conditions, it must be cleaned and lubricated.

CLEANING AND MAINTENANCE CONTINUED



WARNING: ALWAYS HAVE ADEQUATE VENTILATION. CLEANING FIREARMS IN POORLY VENTILATED AREAS, DISCHARGING FIREARMS, OR HANDLING AMMUNITION MAY RESULT IN EXPOSURE TO LEAD AND OTHER SUBSTANCES KNOWN TO CAUSE BIRTH DEFECTS, REPRODUCTIVE HARM AND OTHER SERIOUS PHYSICAL INJURY. WASH HANDS THOROUGHLY AFTER EXPOSURE.



WARNING: NEVER MANIPULATE, ADJUST OR CHANGE ANY OF THE INTERNAL COMPONENTS OF YOUR FIREARM UNLESS SPECIFICALLY DIRECTED TO DO SO IN THIS MANUAL. IMPROPER MANIPULATION OF ANY INTERNAL COMPONENT MAY AFFECT THE SAFETY AND RELIABILITY OF YOUR FIREARM AND MAY CAUSE SERIOUS INJURY OR DEATH.



WARNING: ANY MAINTENANCE, ADJUSTMENT OR SERVICE NOT SPECIFIED IN THIS MANUAL MAY AFFECT THE SAFETY AND RELIABILITY OF YOUR FIREARM AND MUST BE PERFORMED BY A QUALIFIED GUNSMITH USING GENUINE SMITH & WESSON® PARTS. IF YOU DO OTHERWISE, IMPROPER FUNCTIONING OF YOUR FIREARM MAY OCCUR AND SERIOUS INJURY OR DEATH MAY RESULT.

CAUTION: Always follow the instructions provided with your firearm cleaner and firearm lubricant.

CAUTION: The gas tube will discolor from heat. Do not attempt to remove the discoloration.

CAUTION: Some cleaners can cause damage to your firearm. You should avoid prolonged solvent immersion and prolonged ultrasonic cleaning of your firearm. Choice of solvent should be restricted to those products specifically developed for firearms maintenance. Damage to a firearm's finish may occur if these cautions are ignored. Ammoniated solvents or other strong alkaline solvents, should not be used on any Smith & Wesson® firearm. Cleaning is essential to ensure the proper functioning of your firearm.

- Your firearm is a precision instrument. To ensure reliable function it is necessary to follow a routine maintenance procedure. After firing your firearm, be sure to unload it following the procedure outlined in the section entitled "Inspecting Your Firearm" before performing any cleaning or maintenance procedure.
- Remove any firearm cleaning solution, oil and fingerprints from the outside surfaces of the firearm. (Finger moisture, if left, could start a corrosion process).

CLEANING AND MAINTENANCE CONTINUED

- If your firearm will be used in a cold climate, be sure to use an oil of an appropriate weight so that it will not congeal in cold temperatures, causing the interaction of important parts to be slowed or halted.

MAINTENANCE BEFORE STORAGE

- When storing, do not encase your firearm in anything that will attract or hold moisture, for example, leather or heavy cloth. Also, do not store firearms with a plug inserted in the barrel for this can be a contributing factor to moisture accumulation. If your firearm is to be stored for an extended period, the bore, chamber and internal surfaces should be oiled with a high quality lubricating oil or preservative intended for firearms.
- The external parts; receiver, bolt and barrel should be coated with an anti-rust oil. Before using your firearm again, be sure to clean it. Every time you clean your firearm, check it for signs of wear. If wear is noted, do not use the firearm. Return it to Smith & Wesson® for service or have it checked by a qualified gunsmith.

CAUTION: Use of ammunition manufactured with corrosive primers in this firearm will cause oxidation to develop on any exposed metal parts of the firearm. To prevent such oxidation, the residue from corrosive primers must be completely removed from all exposed metal parts after each time ammunition with corrosive primers is used in this firearm. Conventional oil or solvent-based firearm cleaners WILL NOT dissolve the residue from corrosive primers. Residue from corrosive primers MUST be completely dissolved with a water-based cleaner. After the corrosive residue has been completely dissolved from all exposed metal parts, remove any excess water-based cleaner from the firearm. Finally, lubricate the firearm as instructed in the Safety and Instruction Manual. Failure to follow these instructions will cause damage to the firearm and may affect the ability of the firearm to function properly.

Check with the ammunition manufacturer or a qualified gunsmith if you are unsure whether the particular ammunition you plan to use in this firearm has been manufactured with corrosive primers. If in doubt, follow all the instructions above to prevent oxidation caused by ammunition manufactured with corrosive primers.

Ammunition manufactured by SAAMI member companies do not use corrosive primers.

LIMITED WARRANTY

For Owners Within The United States.

This warranty is granted by Smith & Wesson® Inc. This warranty is effective from the date of purchase and applies to the original owner of any firearm. With respect to such firearms, this warranty supersedes any and all other warranties.

Smith & Wesson® firearms are warranted to be free from defects in material and workmanship. Any such defects of which Smith & Wesson® receives written notice within one year from the date of purchase by the original owner, will be remedied by Smith & Wesson® without charge within a reasonable time after such notification and delivery of the firearm as provided below.

In the event of an emergency (repairs needed by law enforcement, an upcoming match or hunting trip), call 1-800-331-0852, ext. 4125 and ask for 911 Priority Repair Service. This allows you to speak with a Smith & Wesson representative. Immediately upon receipt, your firearm will be assigned to a gunsmith. After the work is completed, we will return your Smith & Wesson® firearm via overnight delivery.

Warranty claims (in writing) and the firearm concerned should be delivered to Smith & Wesson's Customer Service Department, 2100 Roosevelt Avenue, Springfield, Massachusetts 01104. In addition, a copy of the bill of sale in the owner's name, or a copy of ATF Form 4473 indicating date of purchase must be included. It is important that the owner comply with all applicable federal, state and local laws and regulations in the shipment of firearms to Smith & Wesson.

NOTE: See the Contact & Shipping section of this manual for further details regarding returns.

Warranty claims should state the model and serial number of the firearm concerned and the description of the difficulty experienced. It is recommended that shipments be insured by the owner, since Smith & Wesson will accept no responsibility for loss or damage in transit. Transportation and insurance charges for return to owner will be paid by Smith & Wesson® if the claim is covered by the warranty.

UNDER NO CIRCUMSTANCES SHALL SMITH & WESSON BE RESPONSIBLE FOR INCIDENTAL OR CONSEQUENTIAL DAMAGES WITH RESPECT TO ECONOMIC LOSS, INJURY, DEATH OR PROPERTY DAMAGE, WHETHER AS A RESULT OF BREACH OF THIS WARRANTY, NEGLIGENCE OR OTHERWISE.

LIMITED WARRANTY CONTINUED

Some states do not allow the exclusion or limitation of incidental or consequential damages, so the above limitation or exclusion may not apply to you.

Smith & Wesson® will not be responsible for:

- Defects or malfunctions resulting from careless handling, unauthorized adjustments or modifications made or attempted by anyone other than a qualified gunsmith following Smith & Wesson® authorized procedures, or failure to follow the disassembly instructions in the Smith & Wesson® manual.
- Use of defective or improper ammunition, corrosion, neglect, abuse, ordinary wear and tear, or unreasonable use.
- Criminal misuse, negligence or use under the influence of drugs or alcohol.

Smith & Wesson's Lifetime Service Policy begins after the warranty period has expired. Smith & Wesson® will repair, without charge, for the lifetime of the original owner, any Smith & Wesson® handgun purchased on or after February 1, 1989, and any Modern Sporting Rifles, that is found to have a defect in material or workmanship. Eligibility for this Lifetime Service Policy requires returning the Product Registration Card within 30 days of purchase. The Lifetime Service Policy covers functional defects; it does not include the firearm's finish, grips, magazines or sights. The Lifetime Service Policy is in addition to and not an extension of the Smith & Wesson® Warranty.

This warranty gives you specific legal rights. You may also have other rights that vary from state to state.

NOTE: All liability is excluded in the event that the instructions in the Smith & Wesson® manual are not observed.

CONTACT & SHIPPING INFORMATION

For Owners Within The United States.

NOTE: A Return Merchandise Authorization (**RMA**) is the first step in the process of returning a product in order to receive a repair, replacement or refund. Please contact Smith & Wesson's Customer Service Dept. (via e-mail: qa@smith-wesson.com or by phone at 1-800-331-0852 ext. 4125) to obtain authorization to return your firearm so we can process it quickly and efficiently. The **RMA** number that is supplied by Smith & Wesson® must be displayed on the outside of the returned product's packaging; returns without an RMA number will be routed differently which will result in delayed processing.

The issuance of an Return Merchandise Authorization (**RMA**) allows Smith & Wesson® an opportunity to try to diagnose and correct a customer's concerns with the product (such as ammunition problems) before it is returned. Accordingly, please contact us before returning your Smith & Wesson® firearm.

CONTACT CUSTOMER SERVICE

Tel: 1-800-331-0852 • 1-413-781-8300 ext. 4125

E-mail: qa@smith-wesson.com

RETURNS - FOR SERVICE

ALL SMITH & WESSON FIREARMS

Smith & Wesson

2100 Roosevelt Avenue

Springfield, MA 01104

Should your Smith & Wesson® firearm require service, it should be returned to the Smith & Wesson® factory.

- Call or e-mail the Customer Service Dept. for authorization and shipping instructions.
- Ensure that the firearm is unloaded.
- Do not attempt to ship a firearm via US Postal Service; only federally licensed dealers may ship a firearm by US Postal Service.
- DO NOT SHIP ANY AMMUNITION.
- Enclose a letter which includes your full name and address (no P.O. Boxes, please), daytime telephone number, e-mail address, the serial number of the firearm, and details of the problem experienced (stating the brand and type of ammunition used when the problem occurred) or work desired.

CONTACT AND SHIPPING CONTINUED

- Record the serial number before shipping, in case you wish to check on the repair status of your firearm.
- Please remove all custom parts and accessories, such as stocks, special sights and scopes, or slings from your firearm before returning.
- Place the firearm in its original case or in a similarly secure container and pack it securely.
- The package must NOT bear any markings which indicate the identity of the contents.
- It is most important that you comply with federal, state, and local laws and regulations. The following guidelines are meant to help, but you must seek assistance from the appropriate authorities if necessary.
- If your firearm must be replaced, it may be necessary to ship the replacement to a dealer rather than directly to you. You will be requested to furnish a signed FFL (Federal Firearms License) from your dealer in such an instance.
- Warranty repair work will begin upon receipt and examination of the firearm. In the case of repairs or work not covered by the warranty, a quotation covering the cost of the work plus round trip transportation charges will be sent to you. Repairs or modification will be scheduled upon receipt of payment.
- A parts list can be obtained by contacting Smith & Wesson®.



WARNING: YOU MAY PURCHASE ACCESSORIES FOR YOUR SMITH & WESSON® FIREARM. YOU MUST HAVE SOME OF THESE PARTS INSTALLED BY A GUNSMITH QUALIFIED TO PERFORM SERVICE ON SMITH & WESSON® FIREARMS. YOU MUST NEVER ATTEMPT TO MODIFY YOUR FIREARM OR INSTALL REPLACEMENT PARTS IN YOUR FIREARM. ALWAYS USE A QUALIFIED SMITH & WESSON® GUNSMITH EVEN IF THE REPAIR SEEMS SIMPLE.

CUSTOM SERVICE

We understand that Smith & Wesson® gun owners may want to enhance their guns with custom gunsmithing, refinishing or accessories. Our gunsmiths offer specialized services and exclusive products to enhance your shooting experience.

Accessories for your Smith & Wesson® firearm are available from your local Smith & Wesson® Authorized Dealer, or directly from Smith & Wesson®.

Contact the Customer Service Department at 1-800-331-0852, ext. 4125 for information about these services.

When ordering directly from the factory, please provide the following information:

- Model Number
- Dash Number
- Serial Number
- Approximate date of purchase
- Complete Return Address
- VISA/Discover/MasterCard Number & Expiration Date
- For Foreign Orders Only, Fax Number or E-mail Address

MAGPUL® M-LOK® ACCESSORY RAILS



WARNING: ALWAYS ENSURE THAT THE FIREARM IS UNLOADED BEFORE INSPECTING, DISASSEMBLING OR ASSEMBLING (INCLUDING ACCESSORIES) AND ALWAYS KEEP THE MUZZLE POINTED IN A SAFE DIRECTION.

The MAGPUL® M-LOK® Accessory Rail System

Look for the M-LOK® logo that designates genuine M-LOK® system components



FIGURE B1

Rifle shown with M-LOK® rails in place

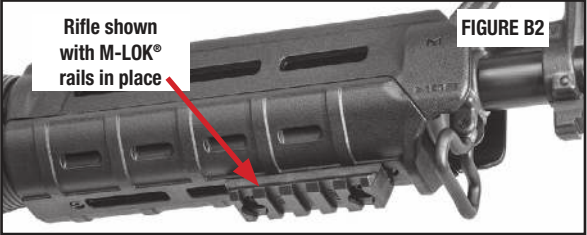

FIGURE B2

- The versatility of the M-LOK® system lies in accommodating various thicknesses of mounting surfaces and the adjustments that allow this functionality, the tips below will help the user to have the best possible results in the fastest possible time.
- Your M-LOK® accessory may arrive with nuts and nylon-patched (thread lock material) screws installed or with the nuts and screws loose with the accessory you have purchased. If the screws are loose, simply thread the nuts onto the screws through the accessory rail as shown (FIGURE B3).

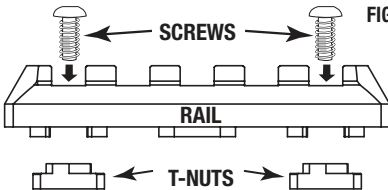

FIGURE B3

- The nylon patch may seem “stiff” for the first installation of the new screws into the T-Nuts. Use a 7mm wrench to hold the T-Nut and to thread it onto the screw, then backing it off to the appropriate clearance adjustment will “break in” the nylon patch, and subsequent use will be easy.

All Rights Reserved. Magpul holds a Trademark on all of its product names and logos. The following products are trademarks of Magpul Industries Corporation, registered in the U.S. and other countries: Magpul, M-LOK.

MAGPUL® M-LOK® ACCESSORY RAILS CONTINUED

- The nylon patch on the screws actually aids function by providing friction to turn the nuts. If you remove and replace the accessory numerous times, the nylon patch may eventually wear. You also may receive an after-market accessory without the patch on the screws. If the nut is not turning appropriately, the patch effect may be restored with either Rocksett™ or Loctite™ blue thread-locker stick. If the screws come without the patch, one of the above products is recommended for best function and durability.

ADJUSTING THE NUT TO THE CORRECT HEIGHT

- For best function, the T-Nut “gap” must be slightly greater than the thickness of the mounting surface (see FIGURE B4). This can be done by measuring the mounting surface thickness directly or using the edge of the mounting surface as a gauge. For most aluminum mounting surfaces setting the nuts as depicted below, with the highest edge of the T-Nut even with the bottom edge of the recoil lug, will provide correct function. Some thicker rails or polymer rails may require the nuts to be looser with a one or two thread(s) gap between the nuts and recoil lugs.

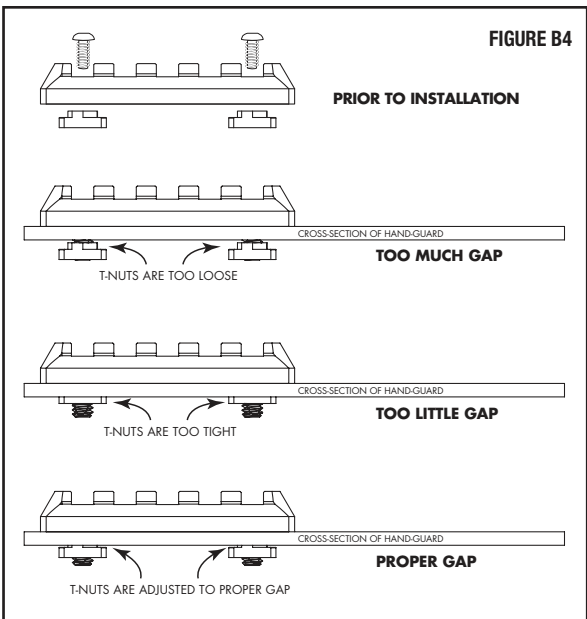

- Some accessories may arrive preset to the condition shown in the illustration for easy installation on aluminum handguards. Remember to loosen the nuts a bit for installation on polymer handguards.

MAGPUL® M-LOK® ACCESSORY RAILS CONTINUED

- Apply some downward force on the hex wrench to make sure that the screw is seated, and then tighten (FIGURE B5).

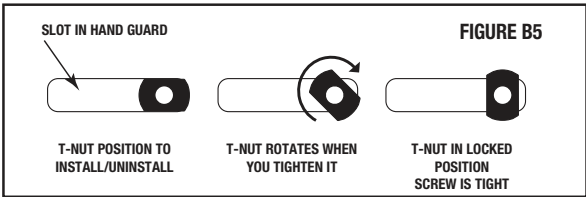

ENSURE THAT THE ACCESSORY IS FULLY SEATED INTO A SLOT AND TIGHTENED INTO POSITION WHEN MOUNTING

- The bottom of the accessory should sit flush with the mounting alignment surface. If it doesn't then slide the accessory fore-aft until it drops fully into the slot with the lugs engaged (FIGURE B6).

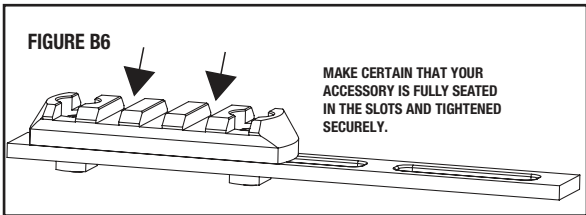

- For maximum repeatability, “bias” the accessory before fully tightening. By bias we mean settle the accessory toward the front where recoil won't give the accessory a “running start” to move when firing.
- To bias the accessory, apply just enough lateral pressure (down and forward) to the accessory to make solid contact with one side and the front (towards muzzle) of the slot, similar to when installing a Picatinny rail accessory. Then tighten all fasteners to the recommended torque spec. This step is not necessary, but aids repeatability.

WARNING: AN ACCESSORY WHICH IS NOT SECURELY MOUNTED MAY BECOME DETACHED UPON RECOIL OF THE FIREARM. IF IT BECOMES DETACHED IT MAY FLY BACK AND STRIKE THE SHOOTER OR A BYSTANDER AND CAUSE INJURY. OBSERVE THE CONDITION OF ALL THE MOUNTING SCREWS AFTER FIRING. IF THE MOUNTING SCREWS SHOW SIGNS OF LOOSENING DO NOT FIRE THE FIREARM AGAIN; TAKE IT TO A QUALIFIED GUNSMITH FOR ASSISTANCE.

MAGPUL® M-LOK® ACCESSORY RAILS CONTINUED

ENSURE THAT THE NUT ROTATES THE FULL 90 DEGREES INTO THE LOCKED POSITION

- If you have adjusted the nuts appropriately, they should rotate into perfect 90 degree alignment with a 1/4 turn of the screw, once it is aligned, the screw draws the nut against the interior of the handguard (FIGURE B7).

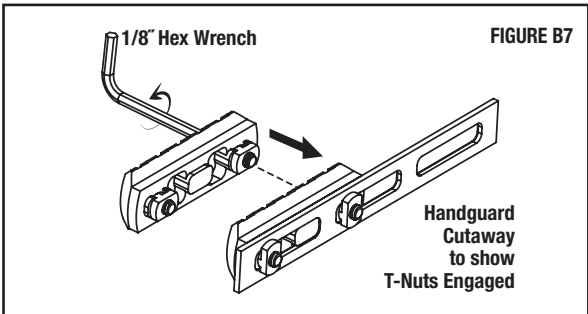

IF THE T-NUTS ARE NOT ROTATING PROPERLY:

- When nuts are spaced too loosely (where they do not contact the interior handguard surface, the nut will rotate freely without stopping and tightening. In this case the nut will have to be screwed in closer to the bottom of the accessory. Simply remove the accessory from the slot and screw the nut on one full turn. Repeat as necessary so that the cam engages the slot when the screw is tightened.
- If the nut is spaced too close to the accessory, then the “wings” of the nut will contact the sides of the slot and the nut will not rotate into place. This will cause the nut to tighten against the accessory lugs without engaging the handguard.
- In this case the nut should be unscrewed until it is spaced far enough away from the lugs to allow it to rotate properly into position. Unscrew the nut one turn at a time and retest function.

NOTE: It is best to observe the T-Nut rotating into locked position, if possible, to be certain that it turns 90 degrees into place and stays there during tightening.

- Most handguards or other mounting surfaces have holes or vents that can be seen through to confirm that the M-LOK® T-Nuts are properly engaged with the slot, and are perpendicular to the slot orientation.

MAGPUL® M-LOK® ACCESSORY RAILS CONTINUED

- If the nut won't rotate, or it rotates too freely to engage the handguard, you may need to hold or turn the nut with a 7mm open-end wrench (FIGURE B8).

- If it is not possible to watch the nut rotate, then careful attention needs to be paid to the screw as it is tightened. The screw should turn easily for the first quarter turn, then when the nut stops rotating it will become slightly more difficult to turn. Continue tightening until secure. Pull on both ends of the accessory to ensure it is engaged correctly.

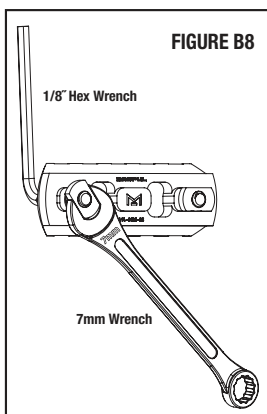

THE M-LOK® SYSTEM TORQUE SPECS

- For attaching polymer accessories to metal handguards: 15 in/lbs.
- For attaching polymer or metal accessories to polymer handguards: 15 in/lbs.
- For attaching metal accessories to metal handguards: 35 in/lbs.
- The installation torque values are not minimums, they are recommended limits. The nylon patch compound (thread lock) may slightly affect the torque reading if using an in/lb torque wrench.
- Using a small hex wrench should prevent over-tightening. Remember that the recoil lugs are doing most of the work, and excessive torque on the nuts is not required.

WARNING: APPLYING EXCESSIVE TORQUE TO THE ACCESSORY RAILS AND HANDGUARDS MAY CAUSE DAMAGE TO THEM RESULTING IN AN INSECURE MOUNT. A RAIL OR ACCESSORY WHICH IS NOT SECURELY MOUNTED MAY BECOME DETACHED UPON RECOIL OF THE FIREARM. IF IT BECOMES DETACHED IT MAY FLY BACK AND STRIKE THE SHOOTER OR A BYSTANDER AND CAUSE INJURY. OBSERVE THE CONDITION OF ALL THE RAIL COMPONENTS BEFORE FIRING. IF ANY PART OF THE MOUNT SHOWS SIGNS OF BEING LOOSE, DO NOT FIRE THE FIREARM AGAIN; TAKE IT TO A QUALIFIED GUNSMITH FOR ASSISTANCE.

REMOVAL OF ACCESSORY RAILS

- To remove, simply loosen the accessory mounting screws one full turn and the T-Nuts should loosen and align with the slot to be easily removed.

MAGPUL® M-LOK® ACCESSORY RAILS CONTINUED

- If the T-Nuts snag when passing through the slot, simply pull up gently on the accessory and continue to loosen the screw another 1/4 to 1/2 turn, which should align the T-Nuts with the slot.
- On some polymer mounting surfaces, the T-Nuts may embed slightly into the polymer surface when tightened.
- When removing from polymer surfaces, easiest function is obtained by loosening 1/2 turn or so and then pressing down on the head of the screw with the hex wrench. This will free the T-Nut if it has been over tightened, and you may remove normally after this step.
- If you go too far in loosening before removing the accessory, the T-Nuts may have loosened past the slot to the point that they will not engage and are spinning freely. Turn screw to align, then remove accessory.

IF YOU DON'T HAVE A TORQUE WRENCH THAT MEASURES IN/LB, HERE ARE SOME TORQUE GUIDELINES: 35 in-lb using the long arm of an L-shaped hex wrench (FIGURE B9) with short end of hex wrench in the screw head.

- Standard 2-5/16" hex wrench
 - Apply 15 lb to the end of the wrench
 - Approximately 1/4" deflection at the end of the wrench.
- Long 3-13/32" hex wrench
 - Apply 9 lb. to the end of the wrench
 - Approximately 1/2" deflection and the end of the wrench. 15 in-lb using the long arm of an L-shaped hex wrench (with short end of hex wrench in the screw head).
- Standard 2-5/16" hex wrench
 - Apply 6 1/2 lb to the end of the wrench
 - Approximately 3/16" deflection at the end of the wrench.
- Long 3-13/32" hex wrench
 - Apply 4 lb to the end of the wrench
 - Approximately 1/4" deflection and the end of the wrench. 15 in-lb using the short arm of an L-shaped hex wrench (with the long end of the hex wrench in the screw head).
- Apply maximum force achievable by hand.

BATTERY WARNINGS



WARNING: IF A BATTERY OPERATED ACCESSORY OR ATTACHMENT (I.E. LASER, OPTICAL SIGHT OR FLASHLIGHT, ETC.) IS SUPPLIED OR USED WITH THIS FIREARM, THE FOLLOWING WARNINGS AND INSTRUCTIONS MUST BE ADHERED TO.



WARNING: KEEP BATTERIES AWAY FROM CHILDREN. THERE IS A CHEMICAL BURN HAZARD ASSOCIATED WITH BATTERIES.



WARNING: IF A NEW OR USED LITHIUM BUTTON/COIN CELL BATTERY IS SWALLOWED OR ENTERS THE BODY, IT CAN CAUSE SEVERE INTERNAL BURNS AND CAN LEAD TO DEATH IN AS LITTLE AS 2 HOURS. ALWAYS COMPLETELY SECURE THE BATTERY COMPARTMENT. IF THE BATTERY COMPARTMENT DOES NOT CLOSE SECURELY, STOP USING THE PRODUCT, REMOVE THE BATTERIES, AND KEEP IT AWAY FROM CHILDREN. IF YOU THINK BATTERIES MIGHT HAVE BEEN SWALLOWED OR PLACED INSIDE ANY PART OF THE BODY, SEEK IMMEDIATE MEDICAL ATTENTION.

- When used correctly, batteries provide a safe and dependable source of portable power. However, misuse or abuse may result in leakage, fire, or explosion.
- Batteries can explode or leak and cause burns if installed backwards, disassembled, charged, or exposed to water, fire or high temperature.
- Always take care to install your batteries correctly observing the “+” and “-” marks on the battery and the device.
- Always replace the whole set of batteries at one time, taking care not to mix old and new batteries, or batteries of different types.
- Store unused batteries in their original packaging and away from metal objects that may short-circuit them.
- Remove discharged batteries from equipment promptly to avoid possible damage from leakage.
- Never dispose of batteries in fire. (Failure to observe this precaution may result in an explosion.)
- The batteries are supplied in a charged state and are not designed for recharging. Recharging may cause leakage, fire, or explosion.
- The batteries should be disposed of properly, including keeping them away from children.
- Dispose of used batteries immediately. Even used batteries may cause injury.

PATENT INFORMATION

- This product may be covered by one or more patents.
Visit www.smith-wesson.com for virtual patent information.



Smith & Wesson®

EMPOWERING AMERICANS™



3015611

Smith & Wesson®

2100 Roosevelt Avenue • Springfield, MA 01104

www.smith-wesson.com

p/n 3015611

S&W_M&P_CF_MSR_REV051522